

**Technical training.**  
Product information.

## **F82 GTS Complete Vehicle**



TG15-1293

**BMW Service**

Edited for the U.S. market by:  
**BMW Group University**  
Technical Training

ST1601

3/1/2016

# General information

## Symbols used

The following symbol is used in this document to facilitate better comprehension or to draw attention to very important information:



---

Contains important safety information and information that needs to be observed strictly in order to guarantee the smooth operation of the system.

---

## Information status and national-market versions

BMW Group vehicles meet the requirements of the highest safety and quality standards. Changes in requirements for environmental protection, customer benefits and design render necessary continuous development of systems and components. Consequently, there may be discrepancies between the contents of this document and the vehicles available in the training course.

This document basically relates to the European version of left hand drive vehicles. Some operating elements or components are arranged differently in right-hand drive vehicles than shown in the graphics in this document. Further differences may arise as the result of the equipment specification in specific markets or countries.

## Additional sources of information

Further information on the individual topics can be found in the following:

- Owner's Handbook
- Integrated Service Technical Application.

Contact: [conceptinfo@bmw.de](mailto:conceptinfo@bmw.de)

©2015 BMW AG, Munich

## Reprints of this publication or its parts require the written approval of BMW AG, Munich.

The information contained in this document forms an integral part of the technical training of the BMW Group and is intended for the trainer and participants in the seminar. Refer to the latest relevant information systems of the BMW Group for any changes/additions to the technical data.

Information status: **October 2015**  
Technical Training

# F82 GTS Complete Vehicle

## Contents

<b>1.</b>	<b>Introduction</b> .....	<b>1</b>
1.1.	History.....	2
1.1.1.	E30 M3 Sport Evo II.....	2
1.1.2.	E36 M3 GT.....	3
1.1.3.	E46 M3 CSL.....	4
1.1.4.	E92 M3 GTS.....	5
1.1.5.	E90 M3 CRT.....	6
1.1.6.	F82 M4 MotoGP SAFETY CAR.....	7
1.2.	Vehicle fact sheet F82 M4 GTS.....	8
<b>2.</b>	<b>Technical Data</b> .....	<b>10</b>
<b>3.</b>	<b>Body</b> .....	<b>12</b>
3.1.	Bodyshell.....	12
3.2.	Exterior.....	13
3.2.1.	Front view.....	13
3.2.2.	Side view.....	16
3.2.3.	Rear view.....	17
3.2.4.	Exterior colors.....	22
3.3.	Interior.....	23
3.3.1.	Driving area and steering wheel.....	23
3.3.2.	Seats and seat belts.....	26
3.3.3.	Door trim panels.....	29
3.3.4.	Rear parcel shelf.....	29
3.3.5.	Sound insulation.....	29
3.3.6.	Roll bar.....	30
<b>4.</b>	<b>Drive</b> .....	<b>31</b>
4.1.	S55B30T0 engine.....	31
4.1.1.	Engine mechanics.....	31
4.1.2.	Oil supply.....	32
4.1.3.	Service information.....	32
4.1.4.	Water injection.....	32
4.2.	Engine electrical system.....	47
4.2.1.	Engine control.....	47
4.3.	Fuel supply.....	51
4.4.	Exhaust system.....	51
4.5.	M DCT Drivelogic.....	53
4.5.1.	M DCT Drivelogic and MDrive.....	54
4.5.2.	Launch Control.....	55
4.5.3.	Wheelspin start.....	56

# F82 GTS Complete Vehicle

## Contents

4.5.4.	Emergency gearbox release.....	57
4.5.5.	Service information.....	57
4.6.	Rear axle final drive.....	58
4.6.1.	Active M differential.....	58
4.6.2.	Service information.....	59
<b>5.</b>	<b>Chassis and Suspension.....</b>	<b>60</b>
5.1.	Front axle and rear axle.....	60
5.1.1.	Front axle.....	61
5.1.2.	Rear axle.....	63
5.2.	Adjustable high-performance chassis and suspension.....	64
5.2.1.	Stepless lowering.....	64
5.2.2.	Rebound.....	66
5.2.3.	Compression stage.....	68
5.3.	Wheel alignment.....	69
5.3.1.	Axle setting data.....	69
5.3.2.	Procedure.....	69
5.4.	Brakes.....	72
5.5.	Wheels and tires.....	73
5.5.1.	Wheels.....	74
5.5.2.	Cup tires.....	74
<b>6.</b>	<b>Vehicle Electrical System.....</b>	<b>78</b>
6.1.	Active Sound Design ASD.....	78
6.2.	Heating and air conditioning system.....	78
6.3.	Radio and speaker system.....	78
<b>7.</b>	<b>Information for Service.....</b>	<b>81</b>
7.1.	F82 M4 GTS.....	81
7.2.	Replacement part orders.....	81
7.3.	Body.....	81
7.4.	Seat belts.....	81
7.5.	S55B30T0 engine.....	82
7.6.	Water injection.....	82
7.7.	M DCT.....	82
7.8.	Launch Control and wheelspin start.....	83
7.9.	Active M differential.....	83
7.10.	Adjustable high-performance chassis and suspension.....	83
7.11.	Wheel alignment.....	84
7.12.	Tires.....	84

# F82 GTS Complete Vehicle

## 1. Introduction

For customers with especially high performance demands, BMW M GmbH now offers the extreme sports car successor based on the BMW M4 Coupé, the BMW M4 GTS. Like its predecessor, the E92 BMW M3 GTS, the BMW M4 GTS is also suitable for driving at club sport events. The BMW M4 GTS is produced by the BMW M GmbH manufacturing facility and is offered as a perfectly matched and individually produced package. The modifications for club sport use include the drive, chassis and suspension technology, vehicle electrical system as well as exterior and interior body equipment. The market introduction of the BMW M4 GTS will take place in March 2016.

With its exclusive offering for motor sports enthusiasts, BMW M GmbH continues a tradition that was already established with the earlier generations of the BMW M3. The outstanding sporty potential of the BMW M4 Coupé has been exploited and consistently further developed once more. Customers benefit from the extensive know-how of the company in the field of development and production of racing vehicles. Thank to targeted modifications to improve performance and safety, the BMW M4 GTS is ready for driving on the race track in club sport competition and at the same time offers the possibility of vehicle type approval for street use. The driver can thus make his way to the race track in his own sports vehicle or can also use the car to drive to work.

This BMW Sports Coupé based on the F82 is intended for the ECE, US and Asian markets. Production of left and right-hand drive vehicles is planned. The first vehicle will be built at the start of 2016 and production will end after approx. 700 units worldwide are produced. The vehicles will be built on the production installations on the basis of the F82 and then finished and fine-tuned by a supplier (EDAG Engineering GmbH).



F82, BMW M4 GTS

Consistently purist design, adjustable aerodynamic elements, increased performance through water injection for the turbocharged six-cylinder high-revving in-line engine, as well as chassis and suspension technology designed to meet the demands of driving on the race track mean that the BMW M4 GTS occupies a leading position among high-performance vehicles designed for club sport events.

The visual differentiation in comparison with the BMW M4 Coupé includes exterior components finished in matt black such as the BMW kidney grille and roof strips as well as the side gill elements in dark-anodized chrome on the BMW M4 GTS (BMW M4 Coupé in chrome).

Only the differences of the F82 M4 GTS in comparison with the F82 M4 Coupé will be described here.

# F82 GTS Complete Vehicle

## 1. Introduction

### 1.1. History

#### 1.1.1. E30 M3 Sport Evo II

1990

The BMW M3 Sport Evo II wins 15 national and international championships. The limited production run of 600 Evo II with catalytic converter and 238 hp (S14B25) is quickly sold out.



TG15-1295

E30, BMW M3 Sport Evo II



# F82 GTS Complete Vehicle

## 1. Introduction

### 1.1.2. E36 M3 GT

1994

The homologation series of the BMW M3 GT (Coupé only) with a power output of 295 hp (S50B30) is produced in a limited series of 350 vehicles. The M3 GT is delivered only in the color “British Racing Green” (color code 312); only one vehicle was built in Silver. A rear spoiler was standard and the doors were made of aluminium. Steve Soper, Joachim Winkelhock and Jonny Cecotto win the touring car world championship title.



E36, BMW M3 GT

# F82 GTS Complete Vehicle

## 1. Introduction

### 1.1.3. E46 M3 CSL

2002

With the BMW M3 CSL with 360 hp (S54B32HP) produced in a limited series of 1,383 units, BMW M shows how a high-powered vehicle can be further optimised through the use of lightweight construction materials in an intelligent lightweight construction. Features available here for the first time include M track mode (today called M dynamic mode), SMG Launch Control (automatic upshifts in S mode shortly before maximum engine speed), an electronic oil-level check, Michelin Cup tires and the Run Flat Indicator RPA.



TG13-2561

E46, BMW M3 CSL



# F82 GTS Complete Vehicle

## 1. Introduction

### 1.1.4. E92 M3 GTS

2010

As a low-volume production series for customers who take part in club sport events, BMW M GmbH offered the M3 GTS. The extreme sports car underwent modifications in the drive and chassis and suspension, as well as in the interior equipment and the body in order to meet the requirements in club sports. The power of the high-speed S65B44 was raised to 450 HP.



TG10-0269

E92, BMW M3 GTS

# F82 GTS Complete Vehicle

## 1. Introduction

### 1.1.5. E90 M3 CRT

2011

On the basis of the E90 BMW M3 Sedan, M GmbH offered the BMW M3 CRT (Carbon Racing Technology) from 2011. On the BMW M3 CRT, as previously on the BMW M3 GTS, the vehicle weight was reduced by approx. 70 kg/154 lbs compared with the BMW M3 by the use of carbon. The BMW M3 CRT was built and delivered to customers as a small series of only 67 vehicles. The power data of the S65B44 corresponds to the figures of the E92 BMW M3 GTS.



E90, BMW M3 CRT

# F82 GTS Complete Vehicle

## 1. Introduction

### 1.1.6. F82 M4 MotoGP SAFETY CAR

2015

The BMW M4 MotoGP Safety Car was built in 2015 on the basis of the F82. This MotoGP Safety Car already included a number of technologies now also featured in the F82 M4 GTS.



F82, BMW M4 MotoGP SAFETY CAR

The BMW M4 MotoGP Safety Car already included the following F82 BMW 4 GTS technologies:

- Front splitter
- Water injection
- Coilover suspension
- Rear spoiler made of carbon-fiber-reinforced plastic
- Exhaust system made of titanium with purist exhaust tailpipes made of titanium

# F82 GTS Complete Vehicle

## 1. Introduction

### 1.2. Vehicle fact sheet F82 M4 GTS



F82, BMW M4 GTS

# F82 GTS Complete Vehicle

## 1. Introduction

- **Design and Aerodynamics:** 2-door high-performance sports coupé is designed for customers who want to take part in club sport events. M-specific characteristics in front, side and rear area. Unique aerodynamic design in front, side and rear area and vehicle underbody. Aerodynamics can be adapted to the customer depending on situation. Consistent lightweight construction in the entire interior and exterior body area.
- **Engine/Transmission:** 3-liter 6-cylinder TVDI engine with water injection for increased performance. Efficient, with even more powerful and more spontaneous linear power development. Fuel and oil supply designed for maximum g loads in club sport. 7-speed M double-clutch transmission with Drivelogic. Electronically controlled M rear-axle differential lock. Consistent lightweight construction in the drive area.
- **Steering:** Direct and precise, variable M Servotronic (EPS) with Servotronic support (in three stages). M steering wheel in Alcantara including 12 o'clock marking, M shift paddles and MDrive buttons.
- **Chassis and Suspension/Chassis and Suspension Dynamics Design:** M chassis is standard equipment. 3-way adjustment by the customer possible for adaptation to the respective club sport circuits. Club tires on forged 19" wheels at front and 20" wheels at rear as standard. Optimal driving precision and adapted interplay of steering, tires, suspension and damping action according to the customer's wishes. M carbon ceramic brake for optimum braking power on the race track.
- **Seating Comfort:** Fully adjustable BMW M bucket seats with three-point seat belts.



# F82 GTS Complete Vehicle

## 2. Technical Data

Designation	E92 M3 GTS	F82 M4 Coupé	F82 M4 GTS
Year	2010/2011	06.2014 –	2016
Length [mm]	4,645	4,687	4,689
Width [mm]	1,804	1,870	1,870
Width (mirrors) [mm]	1,976	2,014	2,014
Height [mm]	1,387	1,383	1,383
Seats	2	4	2
Engine type	V8 S65B44M0	R6 S55B30T0	R6 S55B30T0
Cubic capacity [cm <sup>3</sup> ]	4,361	2,979	2,979
Bore [mm]	92	84.0	84.0
Stroke [mm]	82	89.6	89.6
Power [kW/HP] at speed [rpm] Max. engine speed	331/ <b>444</b> 8,300 8,400	317/ <b>425</b> 5,500–7,300	368/ <b>493</b> 6,250
Torque [Nm/lb-ft] at speed [rpm]	440/325 3,750	550/406 1,850–5,500	600/443 4,000–5,500
Type of transmission	M DCT Drivelogic GS7D36SG (+ 1 liter oil)	M DCT Drivelogic GS7D36BG ****	M DCT Drivelogic GS7D36BG
Fully variable M differential lock Rear-axle ratio [:1]	yes 3.15:1	yes Active M differential 3.462:1	yes Active M differential 3.462:1
Vehicle curb weight [kg/ lbs]	1,605/3,530	1,642/3,620	1,637/3,610
Gross vehicle weight [kg/lbs]	1,880/4,144	2,040/4,497	1,901/4,190
Acceleration 0-100 km/ h [s] (0-60 mph)	4.4	4.1 (3.9)	3.8 (3.6)
V <sub>max</sub> [km/h/mpH]	305**/190	250**/155 280/174***	305**/190
Chassis and suspension	Basis E92 BMW M3 Rigidly bolted rear axle support, height-adjustable threaded chassis; Adjustable compression and rebound of the dampers.	Basis F82 BMW M4 Coupé	Basis F82 BMW M4 Coupé Rigidly bolted rear axle support, height-adjustable threaded chassis; Adjustable compression and rebound of the dampers.
Steering Turning Circle [m]	12.5	12.2	12.2

# F82 GTS Complete Vehicle

## 2. Technical Data

Designation	E92 M3 GTS	F82 M4 Coupé	F82 M4 GTS
Brake discs [mm] Diameter x Thickness			
front	378 x 32	380 x 30	400 x 38
rear	380 x 28	370 x 24	380 x 28
Brake caliper type, front	6-piston fixed caliper	4-piston fixed caliper	6-piston fixed caliper
Brake caliper type, rear	4-piston fixed caliper	2-piston fixed caliper	4-piston fixed caliper
Standard tires, front	255/35 ZR 19	255/40 ZR 18	265/35 ZR 19
Standard tires, rear	285/30 ZR 19	275/40 ZR 18	285/30 ZR 20
Front wheels	9 J x 19 light alloy	9 J x 18 light alloy	9.5 J x 19 light alloy
Rear wheels	10 J x 19 light alloy	10 J x 18 light alloy	10.5 J x 20 light alloy
Wheelbase [mm]	2,760	2,812	2,812
Track width, front [mm]	1,546	1,579	1,596

\*\* Electronically regulated \*\*\* SA 7ME M Driver Package. \*\*\*\* as optional equipment.

# F82 GTS Complete Vehicle

## 3. Body

### 3.1. Bodyshell

The bodyshell largely corresponds to the series body of the F82 M4 Coupé. Special mounting points are required to fit the GTS-specific equipment. These include:

- Mounting for the roll bar front right and left
- Mounting for the roll bar at rear right and left
- Heel panels for mounting the rear bench cover at front

The GTS-specific mounts are welded onto the bodyshell.

# F82 GTS Complete Vehicle

## 3. Body

### 3.2. Exterior

#### 3.2.1. Front view

The bumper panel in the M-specific design corresponds to the bumper panel of the F82 BMW M4 Coupé. In order to optimize the air flow and downforce adaptation corresponding to demands, the F82 M4 GTS is equipped with a motor sports-oriented front splitter to increase the downforce in the front area of the vehicle. The front splitter is weight-optimized and is made of carbon-fiber-reinforced plastic. It is bolted together with the bumper panel in exposed carbon look and is always provided with an "Acid Orange" outer edge regardless of the chosen vehicle exterior color.

The frame and the double-bridge longitudinal bars of the BMW M kidney grille are finished in high-gloss black as standard for the F82 M4 GTS and are provided with the M4 model designation.



F82 GTS, front view

The front splitter has two different adjustment positions so that the F82 M4 GTS can also be driven on public roads with sufficient ground clearance:

- Street setting
- Race track setting

# F82 GTS Complete Vehicle

## 3. Body



Street setting



Race setting

The prescribed settings for the front spoiler during street use as well as the recommendations for motor sports settings and tightening torques are described in the Supplementary Owner's Handbook.



# F82 GTS Complete Vehicle

## 3. Body

### Hood

The hood is made of carbon-fiber-reinforced plastic on the F82 M4 GTS.

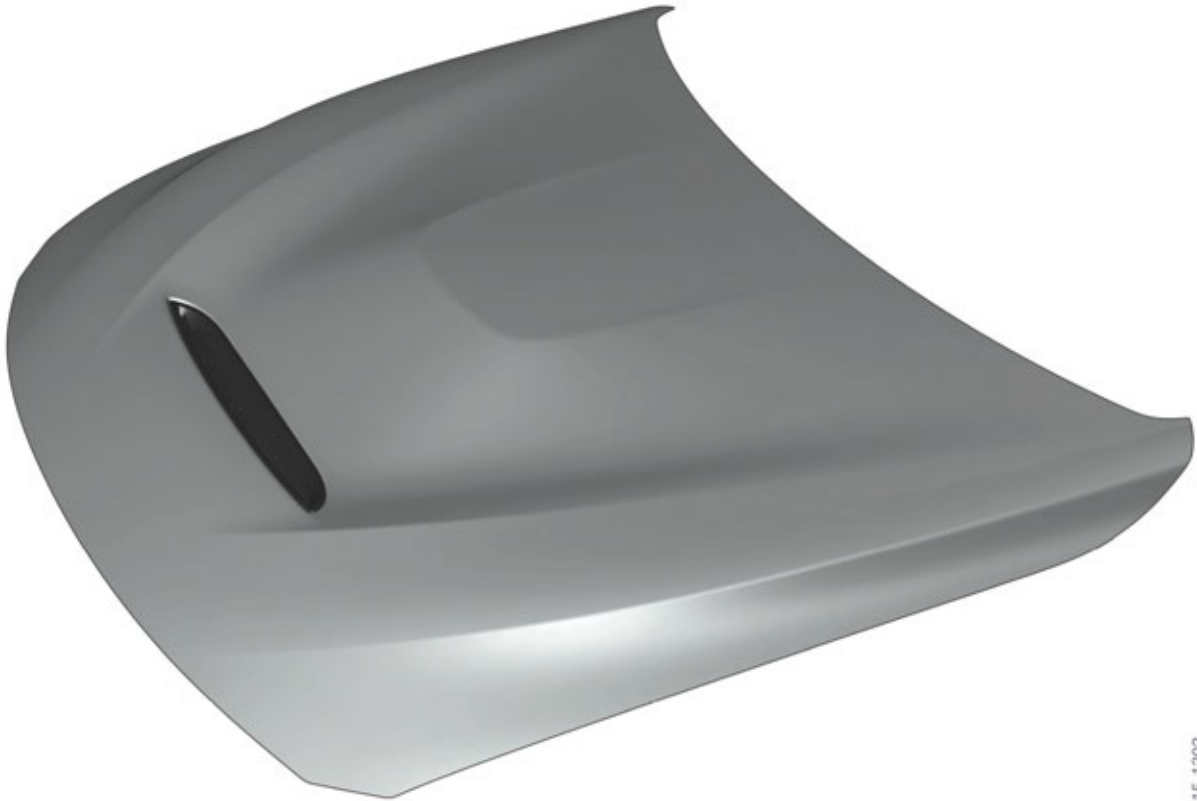

TC15-1302

F82 GTS, CFRP hood

This hood structure makes it possible to achieve strength properties that are normally only possible with a steel design. However, the hood of the F82 M4 GTS is made of carbon-fiber-reinforced plastic and weighs 25% less than the hood made of aluminium on the F82 M4. The CFRP hood thus also contributes to the lightweight construction concept of the new F82 M4 GTS.

The hood also performs engine cooling tasks with its F82 M4 GTS-specific openings and its aerodynamic design additionally supports the downforce at the front end.

# F82 GTS Complete Vehicle

## 3. Body

### 3.2.2. Side view



F82 GTS, side view, rear spoiler winglets mounted for Euro specification

# F82 GTS Complete Vehicle

## 3. Body

### 3.2.3. Rear view



F82 GTS, rear view

In order to optimize the air flow and permit downforce, the F82 M4 GTS is equipped with motor sports-oriented rear wing spoiler as well as a diffuser at the rear. These contribute to the aerodynamic properties of the vehicle to match the specific track profile and other conditions when it is used on the race track.

# F82 GTS Complete Vehicle

## 3. Body

### Rear diffuser



TG15-1305

F82 GTS, diffuser

The diffuser is made of carbon-fiber-reinforced plastic and its aerodynamic design helps to increase the downforce at the rear end of the vehicle.

# F82 GTS Complete Vehicle

## 3. Body

### Rear spoiler winglets US design

The rear spoiler system is based on the spoiler used on the E90 BMW 320si used in the World Touring Car Championship WTCC.



F82 GTS, rear spoiler winglets US version



**Note:** In the US there is a specification for the minimum viewable angle for the center mounted brake light, so the positioning of the rear spoiler winglets had to be repositioned so the visibility of the brake light was not impaired. Therefore, the winglets on all US spec vehicles will be the reverse of the ECE vehicles. This has no functional difference for the aerodynamics of the rear spoiler.



# F82 GTS Complete Vehicle

## 3. Body



TG15-1306

F82 GTS, rear spoiler winglets ECE version, shown in race position 2

The rear spoiler of the F82 M4 GTS is made of Carbon-Fiber-Reinforced Plastic (CFRP) and is supported by aluminium brackets. The trunk is made of Sheet Molded Compound (SMC) and was modified for the rear spoiler. The rear spoiler can be fixed in 3 different positions:

- Street setting drilled hole 1
- 2 different race track settings, drilled hole 2 & 3

# F82 GTS Complete Vehicle

## 3. Body



Street setting on rear spoiler

In general, if the front spoiler is extended from the street position, the inclination angle of the rear spoiler should also be raised. Otherwise, a safe vehicle balance is not guaranteed at higher speeds.

The proper settings for the rear spoiler during street use as well as the recommendations for motor sports settings and tightening torques are described in the Supplementary Owner's Handbook of the F82 M4 GTS.



---

Adjustments to the rear spoiler must be performed only when the trunk is closed. When undoing the screws, it must be ensured that the rear spoiler does not tip down.

---

### **Rear lights in organic LED technology (OLED)**

The rear lights of the F82 M4 GTS are called BMW Organic Light. Organic light-emitting diodes, so-called OLEDs, are used. The OLEDs are composed of thin films of organic molecules that create light with the application of electricity.

# F82 GTS Complete Vehicle

## 3. Body



F82 GTS, OLED rear light

These LEDs are innovative and sustainable light sources which generate light from organic material and also highly energy efficient. In contrast to standard LEDs, OLEDs provide homogeneous light over the full area. Individual activation of OLED segments makes it possible to create a completely new light graphic designs. On the BMW M4 GTS, OLED technology is used both for the tail lights and for the turn indicators.

### 3.2.4. Exterior colors

The F82 M4 GTS is offered exclusively in the exterior color “**Frozen Grey metallic**”.

The customer can additionally order three alternative colors:

- Alpine White
- Black Sapphire metallic
- Mineral Grey metallic

With all exterior colors, certain components are also partially highlighted in “**Acid Orange**” (e.g. wheels, splitter, roll bar).

# F82 GTS Complete Vehicle

## 3. Body

### 3.3. Interior

#### 3.3.1. Driving area and steering wheel

The vehicle curb weight of the F82 M4 GTS is around 3,610 pounds. For this reason, lightweight design was consistently used for many components in the interior. Unnecessary parts such as the rear bench seat was removed and replaced by lightweight covers. The individual measures are described in the chapter "Interior".

#### M driving area



F82 GTS, driving area

The F82 M4 GTS has a center console in lightweight construction with Alcantara covering and contrast stitching. The center console of the F82 M4 GTS is approx. 30% lighter compared with the standard center console of the F82 BMW M4 .



# F82 GTS Complete Vehicle

## 3. Body

### CFRP instrument panel

A support made of CFRP material is used for the first time to support the instrument panel on left-hand drive vehicles. The use of CFRP made it possible to reduce the weight of the instrument panel in the F82 M4 GTS compared with the F82 BMW M4 Coupé.

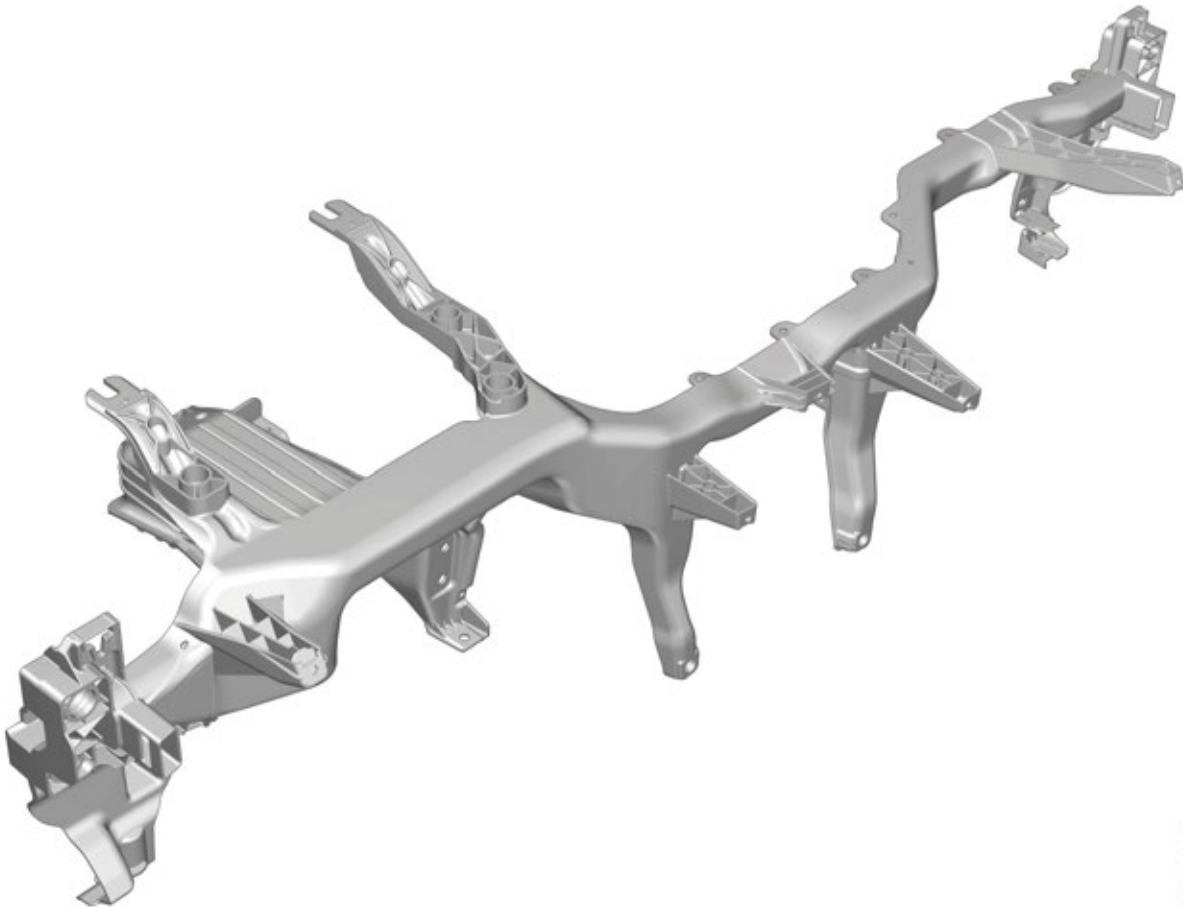

F82 GTS, instrument panel

TG15-1309

# F82 GTS Complete Vehicle

## 3. Body

### M leather steering wheel

The M steering wheel in Alcantara with multifunction capability is designed with a magnesium frame and is based on the steering wheel of the F82 BMW M4 Coupé. Above the thumb rests are the M gearshift paddles with M gearshift logic: downshift on left, upshift on right. A marking was provided at the top center to highlight the 12 o'clock position of the steering wheel. This makes it easier to recognize the center position of the steering wheel when performing rapid steering wheel movements.

Two MDrive buttons M1 and M2 are integrated in the left multifunction button pad on the F82 BMW M4 Coupé.



F82, BMW M4 GTS steering wheel



# F82 GTS Complete Vehicle

## 3. Body

### 3.3.2. Seats and seat belts

Light weight sport bucket seats with integrated apertures are used on the F82 M4 GTS. These bucket seats offer optimum side support through perfect ergonomics as well as optimum support for acceleration and deceleration.

The seat covers are finished in Black Extended Merino leather, and Alcantara. Including embroidered M colors on the head rests.



F82 GTS, seats

# F82 GTS Complete Vehicle

## 3. Body



Integrated apertures in seats

The seats are manually adjustable and include a switch for the electric backrest width adjustment.

### **Seat belts**

Three-point seat belts are offered as standard at the front.

# F82 GTS Complete Vehicle

## 3. Body

### Seat bench

A rear seat bench and the corresponding seat belts were removed. Since the F82 M4 GTS is designed as a club sport vehicle, the rear bench is not needed. The following components are used instead:

- a rear partition wall is made of Glass-Fiber Reinforced Plastic (GFRP) with Alcantara covering
- the rear seat bench cover is made of GFRP with Alcantara covering
- a special floor cover in the rear footwell



TG15-1312

F82 GTS, rear bench cover

These measures made it possible to reduce the weight in the area of the rear seat bench by 40% on the F82 M4 GTS compared with the F82 BMW M4 Coupé.

# F82 GTS Complete Vehicle

## 3. Body

### 3.3.3. Door trim panels

The front door trim panels have been completely redesigned for the F82 M4 GTS. They have a new geometric shape and are made from CFRP. The armrests of the front door trim panel are covered with Alcantara. A race inspired door handle loop with a woven-in M stripe for closing the doors.



F82 GTS, front door trim panel

The use of the new front door trim panels and rear side covers in lightweight construction in the F82 M4 GTS has made it possible to achieve a weight saving of 50% compared with the F82 BMW M4 Coupé.

### 3.3.4. Rear parcel shelf

The storage shelf used in the F82 M4 GTS is the Top HiFi system version from the F82 BMW M4 Coupé. This is necessary because the door speakers and speakers in the rear side trim panels are not installed due to the new door trim panels and side trim panels.

### 3.3.5. Sound insulation

For weight reasons, the sound insulation for the vehicle interior in the F82 M4 GTS has been reduced to the minimum.



# F82 GTS Complete Vehicle

## 3. Body

### 3.3.6. Roll bar

#### Roll bar

A roll bar is used which is installed behind the B-pillar. The roll bar is made of high-strength steel and is provided with foam padding in the upper area. The roll bar is painted in Acid Orange. The roll bar is bolted to the floor of the M4 GTS.



F82 GTS, roll bar with padding

# F82 GTS Complete Vehicle

## 4. Drive

### 4.1. S55B30T0 engine

The familiar S55B30T0 engine from the F82 BMW M4 Coupé is used. By using water injection, it was possible to increase the power to 493 HP and the torque to 600 Nm/443 lb-ft. It was possible to adopt the S55 engine-specific technology, such as the crankcase in closed-deck design, LDS-coated cylinder walls, Valvetronic and twin turbocharging based on the mono-scroll concept with electric wastegate control, from the S55B30T0 engine.



F82 GTS, engine S55B30T0

The technical measures are the use of water injection to increase power as well as ensuring the oil supply when the vehicle is subjected to longitudinal and lateral acceleration forces of 1.4 g. A titanium rear silencer in lightweight construction is used. Like on the F82 BMW M4 Coupé, this is equipped with electric exhaust flaps. The M-typical twin exhaust tailpipes are made of titanium.

#### 4.1.1. Engine mechanics

In comparison with the S55 engine in the F82 BMW M4 Coupé, the S55 engine in the F82 M4 GTS features a modified bedplate. The reinforced bedplate is taken from the competition package of the S55 engine. The bedplate from the competition package has a higher rigidity in order to meet the demands of the higher torque curve of the S55 competition engine.



# F82 GTS Complete Vehicle

## 4. Drive

### 4.1.2. Oil supply

The S55 engine of the F82 M4 GTS is equipped with a longer oil-level sensor. This is necessary since the oil quantity of the S55 engine in the F82 M4 GTS was increased compared with the S55 standard engine. The oil quantity in the oil sump in the S55 engine of the F82 M4 GTS is 6.5 liters compared with 6.0 liters in the S55 engine for the F82 BMW M4 Coupé. It was necessary to increase the oil quantity in order to maintain the oil supply with further increased g forces of up to 1.4 g produced by longitudinal and transverse acceleration in permanent race track operation. Since the oil-level sensor used in the S55 engine for the F82 M4 GTS is restricted by the available installation space, an additional shim is fitted between the oil-level sensor and oil sump.

### 4.1.3. Service information

Like on the F80/F82 and F83, the engine oil is currently replaced at 2,000 km / 1200 miles (running-in check). After this, the running-in check must be reset with the BMW workshop system Integrated Service Technical Application, ISTA.



---

Changed engine oil fill quantity for the S55 engine in the F82 M4 GTS. The fill quantity for an engine oil change with filter is 7.0 liters. Engine oil fill quantity without filter exchange is 6.5 liters.

---



---

The current information and specifications in the Integrated Service Technical Application (ISTA) must be observed.

---

### 4.1.4. Water injection

#### Background

In the middle of the 1930's and at the start of the 1940's in the last century, various attempts were already being made in the field of aeronautics to achieve a simple and effective increase in the performance of combustion engines through turbocharging which could be implemented quickly on demand when requested by the pilot. It was possible to effectively meet this requirement by means of water injection. Since water as a medium also contains bound oxygen and helps cool the combustion chamber, the use of water permits the charge to be increased by the charging pressure in the cylinder so that more power can be generated in a combustion engine. The targeted injection of water, which can also be mixed with alcohol, made it possible to achieve a short-term increase in the output power of the combustion engines by over 40% from a certain charging pressure. This was necessary in particular when the aircraft was climbing or flying at a high altitude where there was already low air pressure. The targeted injection of water or water mixture into the combustion engine then made it possible for the pilot to achieve a short-term increase in power.

After this, water injection was used only very rarely for many decades, until it was again discovered in the 1980's of the last century as a way of achieving a short-term increase in power in Formula 1 cars. This method is still used today in motor sports.

# F82 GTS Complete Vehicle

## 4. Drive

### Function

The distilled water (referred to as "water" below) is carried in a separate supply tank in the vehicle. At a certain operating point (e.g. charging pressure, load, engine speed), the water is drawn in from the supply tank by a pump. The drawn in water is delivered via a line to one or more water injectors. The water injectors, which can be installed in the intake plenum for the intake air, inject finely atomized water so that it can be supplied via the intake channels to the combustion chamber.

With water injection, the engineers exploit the physical property of water whereby it takes the energy required for evaporation from the surrounding area. When the water is injected into the intake plenum as a fine spray mist, its evaporation results in significant cooling of the intake air by approx. 25 °C / 77 °F. As a result, the final compression temperature in the combustion chamber and the knock tendency is reduced. This means that the turbo engine can be operated with a higher charging pressure and earlier ignition point.

### Advantages

- **Efficiency:** Cooling by means of water injection makes it possible to achieve a reduction in combustion temperature in high load ranges. This permits a homogeneous fuel-air mixture and increased efficiency at full load.
- **Emission behavior:** Lower combustion temperatures reduce the production of pollutants, particularly nitrogen oxides (NOx).
- **Reduced knock tendency:** The risk of uncontrolled combustion (so-called knocking) is reduced by the reduction in combustion temperature.
- **Higher compression:** A lower knock tendency makes it possible to increase the compression. This results in optimized efficiency also in the upper partial load range.
- **Dynamic:** An earlier ignition point and higher charging pressure increase the engine power and torque by up to ten percent. An additional increase in power is achieved by the higher oxygen content in cool intake air.
- **Fuel compatibility:** Optimized power output even when using fuel with a lower octane number (RON 95). Turbo engines with direct water injection can be used worldwide.
- **Thermal load:** The cooling effect of water injection reduces temperature influences on the pistons, valves, catalytic converter and turbocharger.

# F82 GTS Complete Vehicle

## 4. Drive

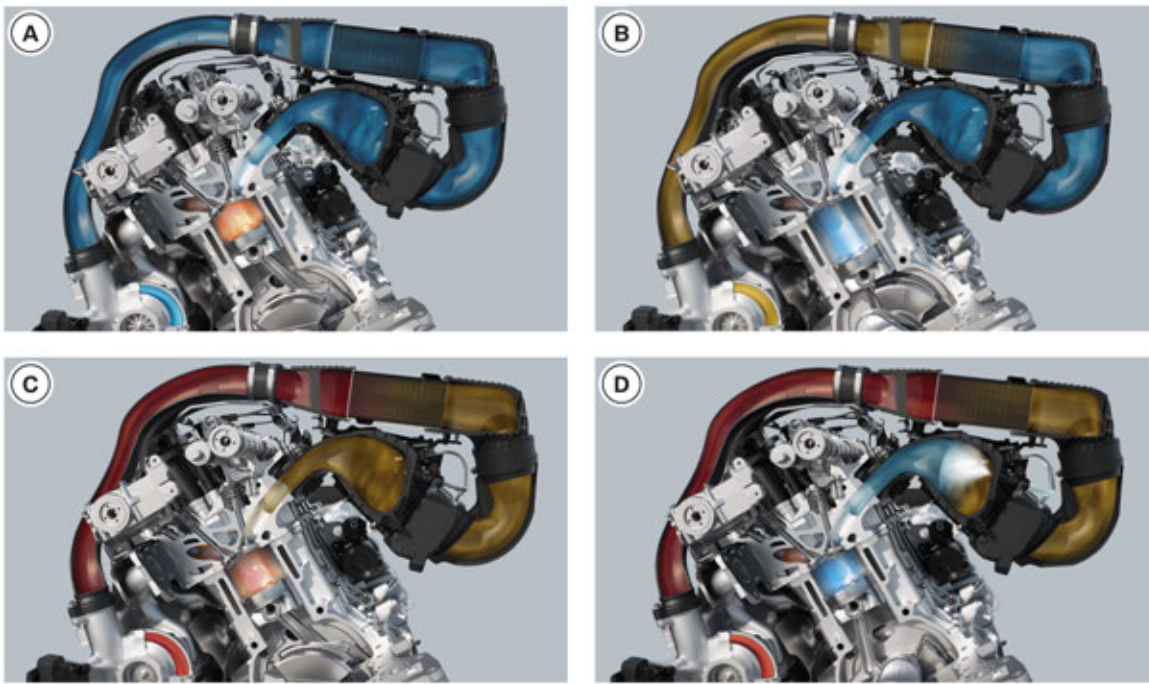

F82 GTS, operating principle of water injection

Index	Explanation
A	Engine under low load
B	Engine under medium load
C	Engine under high load
D	Engine under high load with activated water injection

# F82 GTS Complete Vehicle

## 4. Drive

### Integration

On the F82 M4 GTS, the water supply is ensured by means of a 5-liter / 1.3 gallon water tank. The water tank with cover is located together with the water pump and valve block in a carrier under a cover in the luggage compartment floor at the rear of the vehicle.

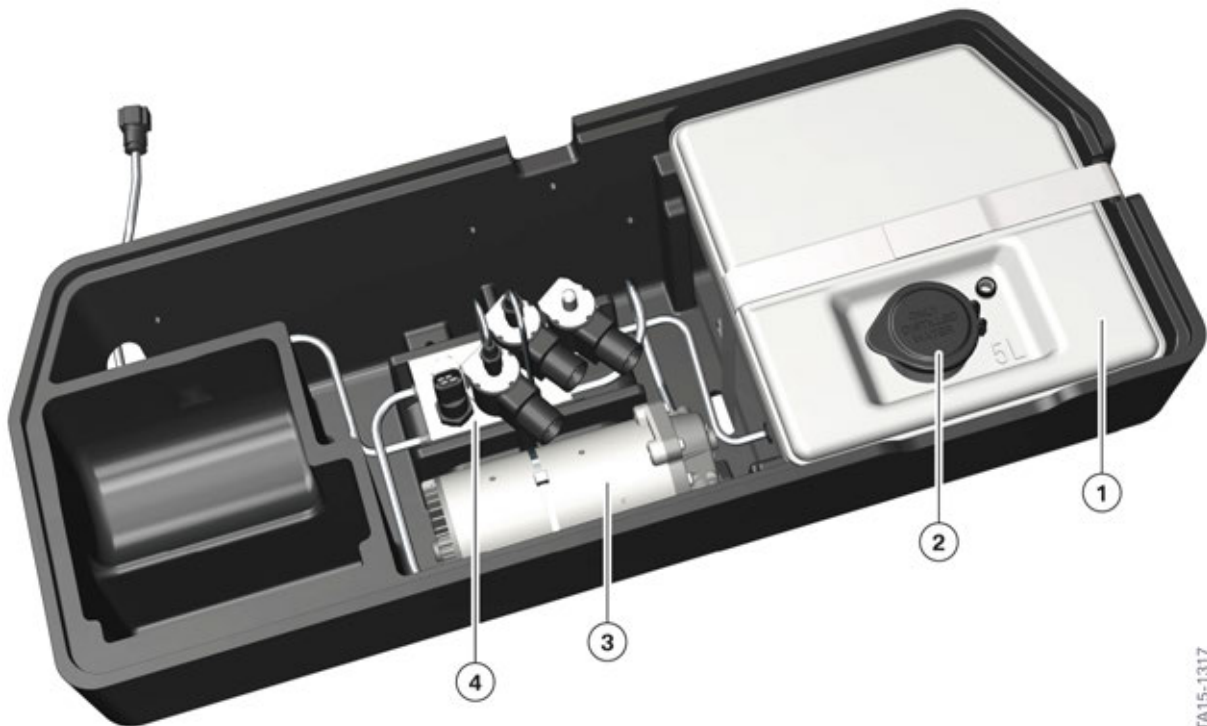

TA15-1317

F82 GTS, water injection system carrier

Index	Explanation
1	Water tank with volume compensation
2	Cover
3	Water pump
4	Valve block

Bulkheads are installed in the water tank. These bulkheads prevent strong water movements in the water tank under extreme driving conditions. In addition, a non-return valve prevents the water from flowing away from the water pump extraction point in the water tank. This allows the water supply to be guaranteed down to a minimum quantity of 300 ml in the water tank. If the temperature should fall below freezing, additional expansion chambers in the upper part of the water tank enable volume compensation of the water upon freezing. This prevents the water tank from being damaged by the water freezing when the tank is full.

# F82 GTS Complete Vehicle

## 4. Drive

A filling level indicator and temperature sensor monitors the water level and water temperature in the water tank. If the water in the water tank falls below the minimum fill quantity of < 1.0 liter / 0.2 gallons, the CC message **“Water injection: Tank reserve level”** is displayed to the driver.



Water injection Tank Reservoir Low Level display in cluster

# F82 GTS Complete Vehicle

## 4. Drive

Water injection is no longer available if the water level in the storage tank drops below the minimum level of 300 ml / 10 ounces. The engine power will then be lowered to the standard power of the S55 engine along with a check control message in the cluster.

The water is supplied from the pump to the water injectors by a line that is routed in the underbody of the F82 M4 GTS. Three water injectors are installed in the intake air plenum. These injectors atomize the water in the intake air plenum that is mixed with air that enters the combustion chamber, there is one injector for every 2 cylinders.

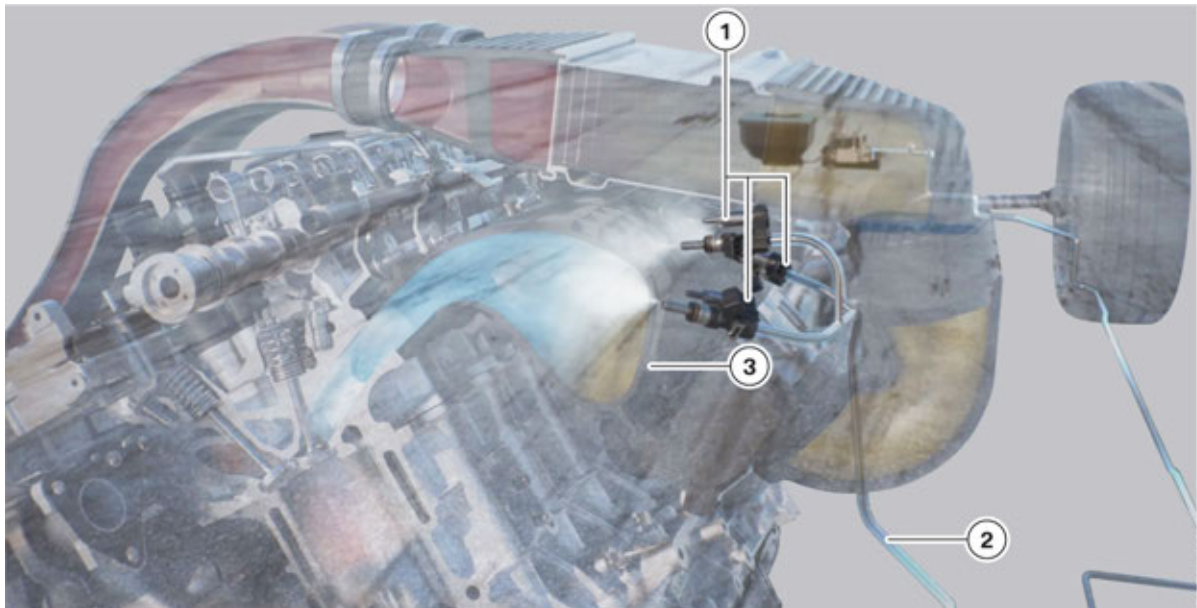

F82 GTS, components for water injection in engine compartment

Index	Explanation
1	Water injectors
2	Supply line
3	Intake plenum

A pump generates the required pressure. A valve block performs water distribution to the water injectors and back to the water tank. A pressure sensor in the feed line in the valve block monitors the pressure in the system.



# F82 GTS Complete Vehicle

## 4. Drive

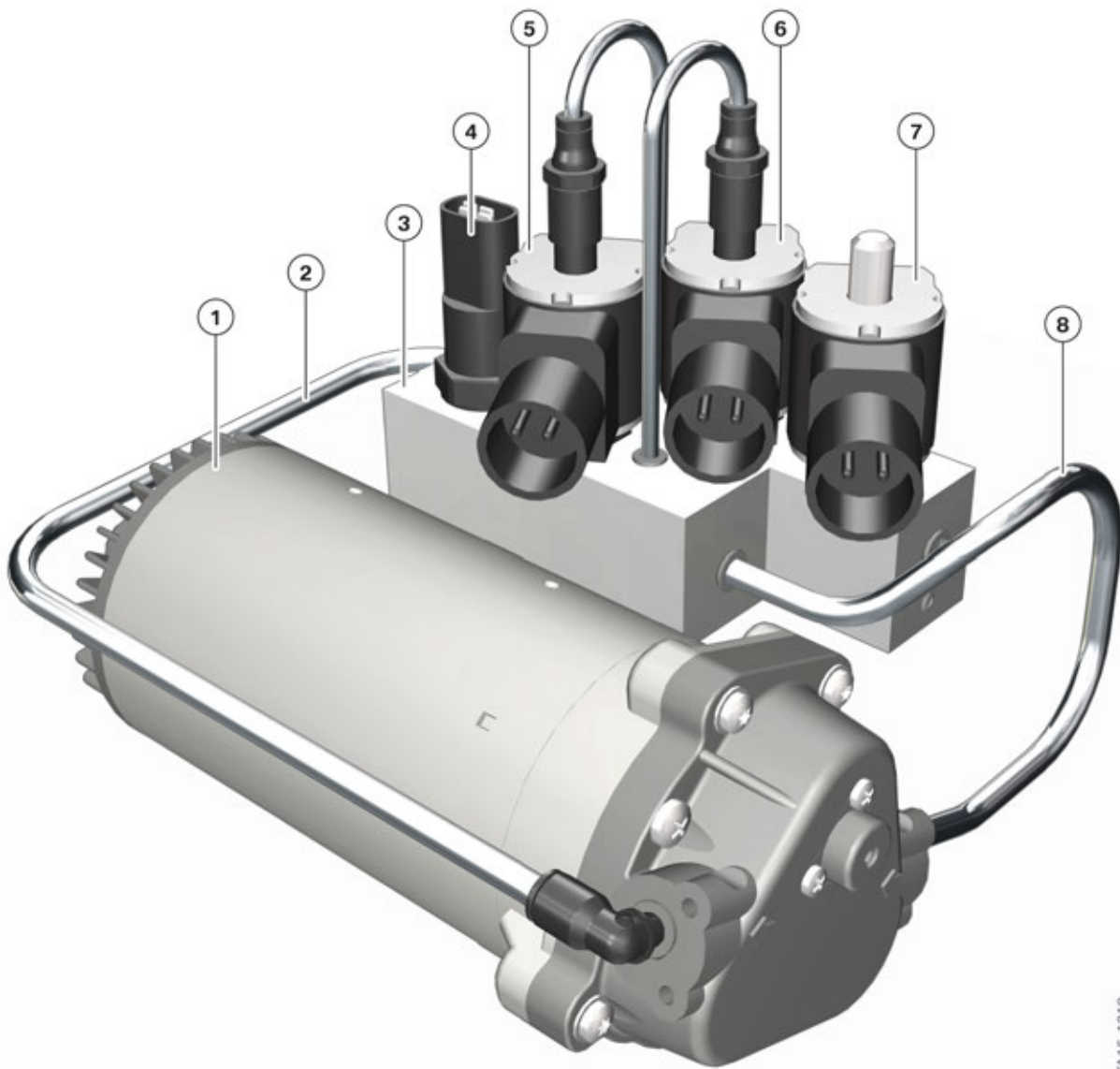

TA15-1319

F82 GTS, pump with valve block for water injection

Index	Explanation
1	Water pump
2	Pressure line
3	Valve block
4	Pressure sensor
5	3/2-way valve 2
6	3/2-way valve 1
7	Shutoff valve
8	Intake pipe

# F82 GTS Complete Vehicle

## 4. Drive

The valve block for water injection contains two 3/2-way valves which control the water flow to the water injectors and back to the water tank. The two valves are required since the running direction of the water pump cannot be reversed. The flow direction of the water is therefore controlled by means of the two 3/2-way valves.

The water pump, shutoff valve and 3/2-way valves are activated via two electric relays, which are correspondingly activated by the DME.

The shutoff valve ensures that:

- the water tank is separated from the system, so that no water can run back into the system after draining.
- the pressure in the system can be maintained.

### System not active

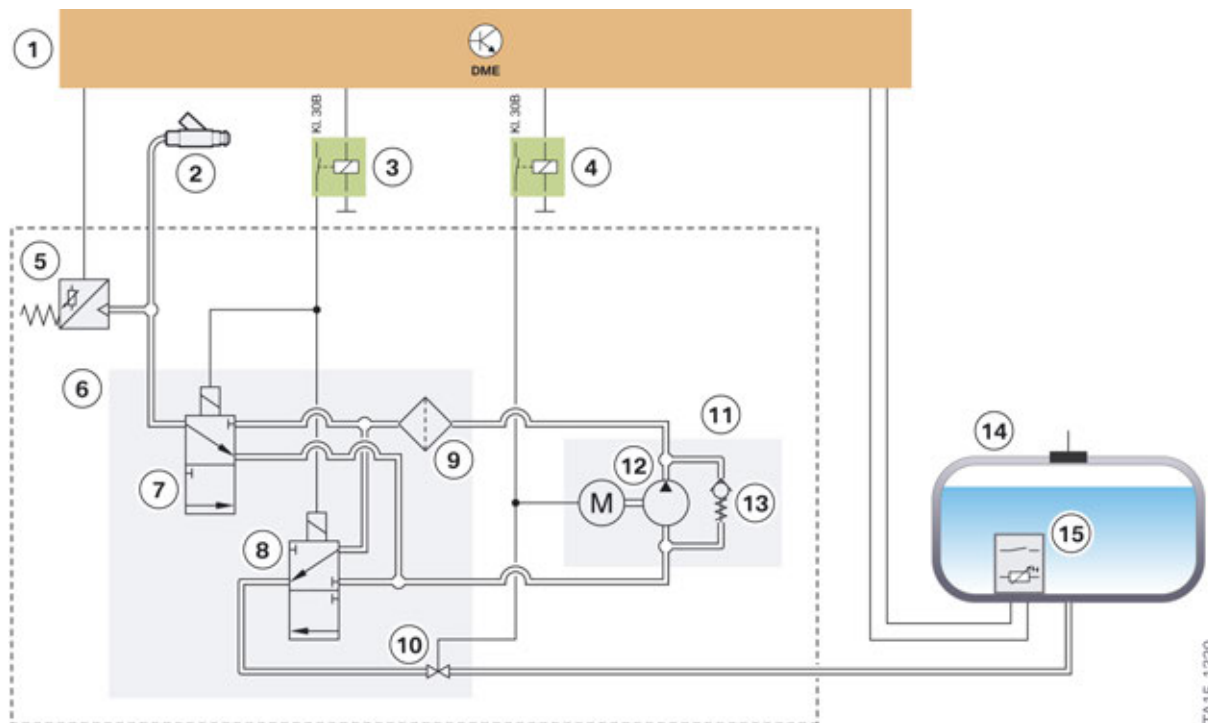

F82 GTS, water injection not active

Index	Explanation
1	DME
2	Water injectors
3	Relay for 3/2-way valves
4	Relay for water pump/shutoff valve
5	Pressure sensor
6	Valve block
7	3/2-way valve 2

# F82 GTS Complete Vehicle

## 4. Drive

Index	Explanation
8	3/2-way valve 1
9	Fine filter 10 µm
10	Shutoff valve
11	Water pump unit
12	Water pump
13	Pressure-limiting valve
14	Water tank
15	Temperature sensor/level sensor

In rest state, when water injection is not active, the relays for controlling the pump, shutoff valve and 3/2-way valves are not activated by the DME and are de-energized.

### Prerequisites

The following prerequisites must be met so that water injection can be activated:

- The engine must be running.
- The engine must be at operating temperature.
- The ambient temperature must be > 5°C / 41 °F.
- The water tank must be filled with "distilled water".
- The fill quantity of the water tank must be > 300 ml / 10 oz.

### System filling and pressure maintenance

If the above prerequisites are met, the system is filled after the engine is started until a pressure of 10 bar is reached. When requested by the DME, the relay for the water pump and shutoff valve is energized by the DME. The water pump is switched on and the shutoff valve is opened. The water pump then draws in water from the water tank and pumps it at a pressure of 10 bar to the water injectors via the 3/2-way valves and the pressure sensor. When a pressure of 10 bar has been reached, the DME switches off the water pump and closes the shutoff valve. The shutoff valve maintains the pressure of 10 bar in the system.

# F82 GTS Complete Vehicle

## 4. Drive

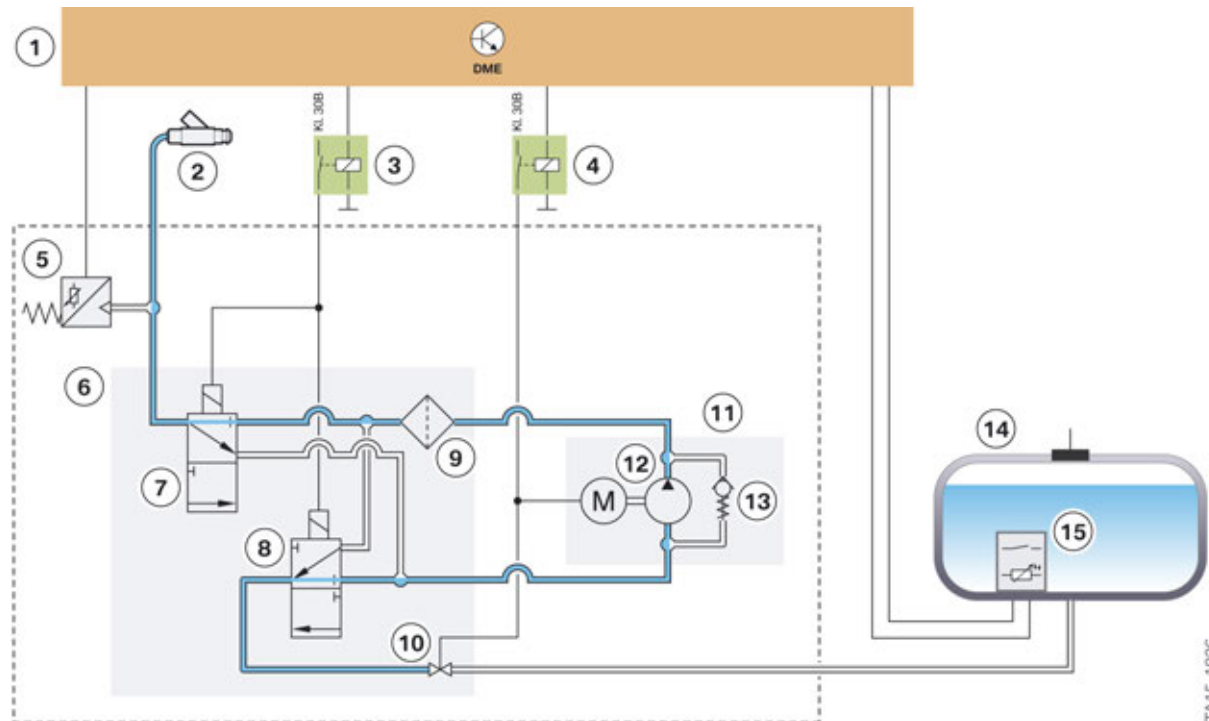

F82 GTS, water injection system filling/pressure maintenance

Index	Explanation
1	DME
2	Water injectors
3	Relay for 3/2-way valves
4	Relay for water pump/shutoff valve
5	Pressure sensor
6	Valve block
7	3/2-way valve 2
8	3/2-way valve 1
9	Fine filter 10 µm
10	Shutoff valve
11	Water pump unit
12	Water pump
13	Pressure-limiting valve
14	Water tank
15	Temperature sensor/level sensor

# F82 GTS Complete Vehicle

## 4. Drive

### System active

If the engine is operated in a load range (full load) and engine speed range (> 5000 rpm) that justifies water injection, the DME requests this. When requested by the DME, the relay for the water pump and shutoff valve is energized by the DME. The water pump is switched on and the shutoff valve is opened. The water pump then draws in water from the water tank and pumps it with a pressure of 10 bar via the 3/2-way valves and the pressure sensor to the injectors, which are activated and are opened by the DME. All three water injectors are operated at a pressure of 10 bar.

The quantity of the water to be injected is controlled by the DME on the basis of a stored characteristic map, which provides the DME information on the load request, engine speed and charging pressure currently present.

The pressure sensor permanently monitors the water pressure in the lines to the water injectors.

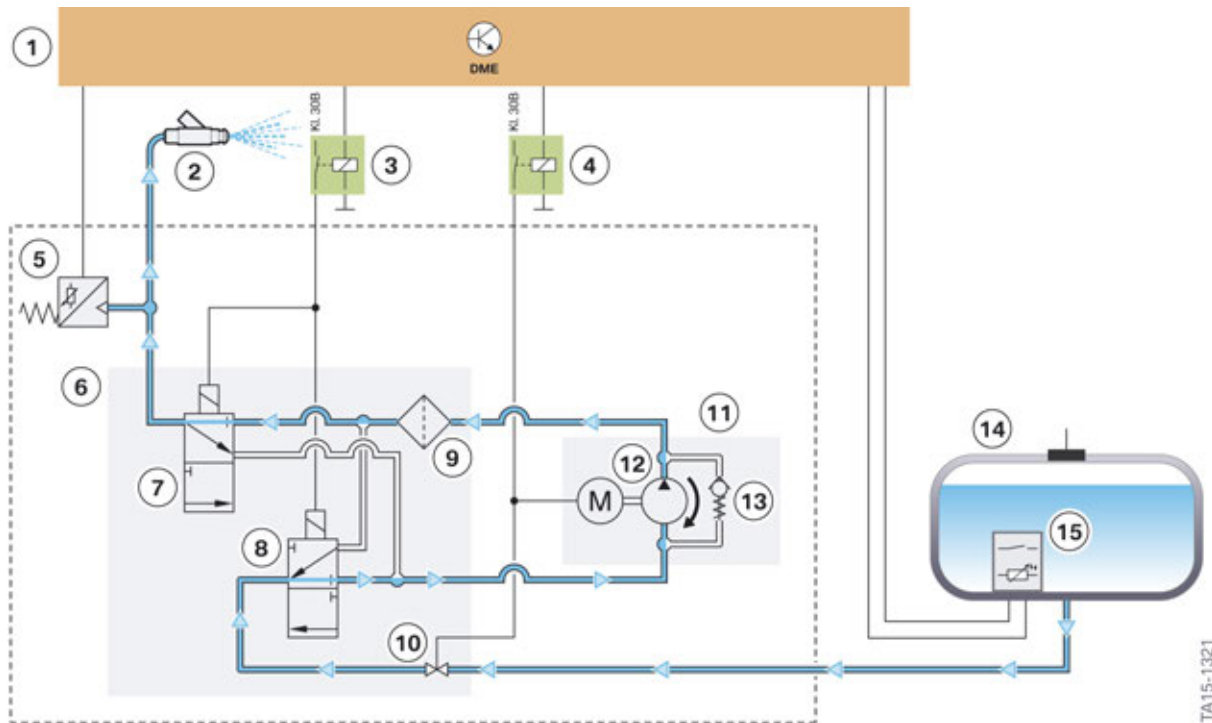

F82 GTS, water injection active

Index	Explanation
1	DME
2	Water injectors
3	Relay for 3/2-way valves
4	Relay for water pump/shutoff valve
5	Pressure sensor
6	Valve block
7	3/2-way valve 2
8	3/2-way valve 1

# F82 GTS Complete Vehicle

## 4. Drive

Index	Explanation
9	Fine filter 10 µm
10	Shutoff valve
11	Water pump unit
12	Water pump
13	Pressure-limiting valve
14	Water tank
15	Temperature sensor/level sensor

If water injection is no longer required at the request of the DME, the water pump is switched off, along with the shutoff valve and water injectors by the relay.

The shutoff valve holds the water in the water pump and in the valve block up to the closed water injectors. This means that it is not necessary to fill the entire system again when water injection is activated once more.

### System draining

The system is drained at the request of the DME if the engine is switched off or if the ambient temperature falls below 5 °C / 41 °F.

When requested by the DME, the relay for the water pump and shutoff valve is energized. Since the running direction of the water pump cannot be reversed, the relay for the two 3/2-way valves and the water injectors is also energized at the same time.

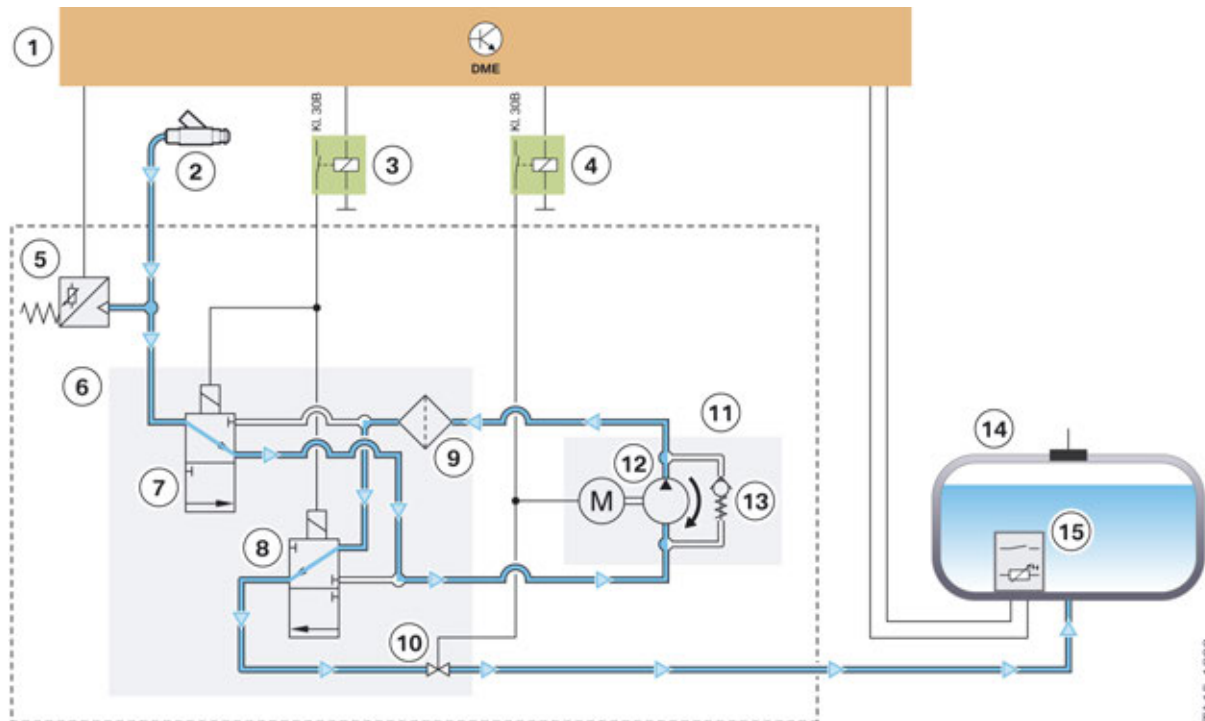

F82 GTS, draining the water injection system

TA15-1322



# F82 GTS Complete Vehicle

## 4. Drive

Index	Explanation
1	DME
2	Water injectors
3	Relay for 3/2-way valves
4	Relay for water pump/shutoff valve
5	Pressure sensor
6	Valve block
7	3/2-way valve 2
8	3/2-way valve 1
9	Fine filter 10 µm
10	Shutoff valve
11	Water pump unit
12	Water pump
13	Pressure-limiting valve
14	Water tank
15	Temperature sensor/level sensor

As a result of the changed position of the two 3/2-way valves, the water is drawn out of the system and delivered back to the water storage tank with the same direction of rotation of the water pump.



When the engine is switched off and the water injection system is drained, operating noises occur which may be heard by the customer. These operating noises cannot be avoided due to the operating principle of the system.

### Component protection

A pressure limiting valve limits the water pressure in the system to protect all components in the event of a malfunction (e.g. obstruction) in the valve block or in the downstream components such as lines and water injectors.

# F82 GTS Complete Vehicle

## 4. Drive

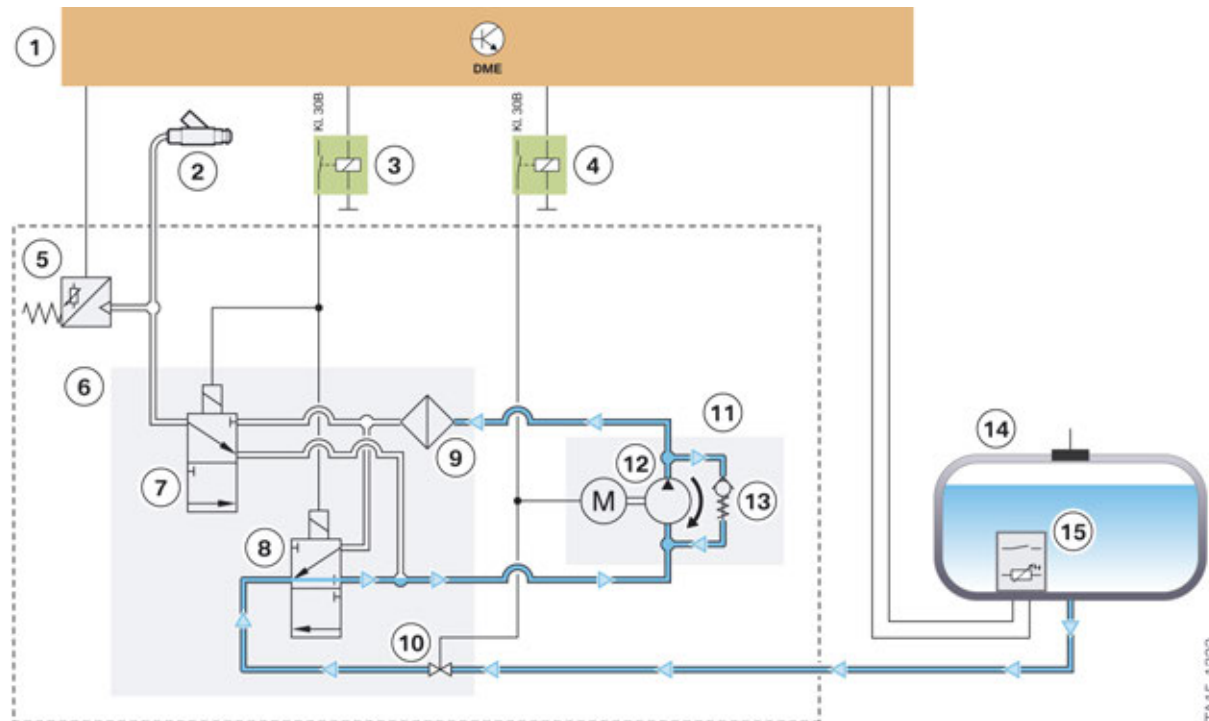

F82 GTS, component protection for water injection system

TA15-1323

Index	Explanation
1	DME
2	Water injectors
3	Relay for 3/2-way valves
4	Relay for water pump/shutoff valve
5	Pressure sensor
6	Valve block
7	3/2-way valve 2
8	3/2-way valve 1
9	Fine filter 10 µm
10	Shutoff valve
11	Water pump unit
12	Water pump
13	Pressure-limiting valve
14	Water tank
15	Temperature sensor/level sensor

# F82 GTS Complete Vehicle

## 4. Drive

### Water consumption

The water consumption depends greatly on the vehicle operating conditions and varies correspondingly. As a rule of thumb, a consumption of 0.6 / – 1 liter per 100 km or 0.15 gallons – 0.26 gallons per 62 miles can be expected on the race track. In the case of dynamic driving (engine speed > 5000 rpm and high load) in everyday use, it will probably be necessary to top up with water at only every 5th refuelling operation.

### Notes

When filling the water injection system, only commercially available distilled water (demineralized - decalcified) must be used for the F82 M4 GTS. Other fluids or mixtures with alcohol is not approved by BMW.

The 10 µm fine filter in the valve block can be removed and installed using the hexagon screw. The fine filter should be replaced at every 2nd oil service/20,000 miles.

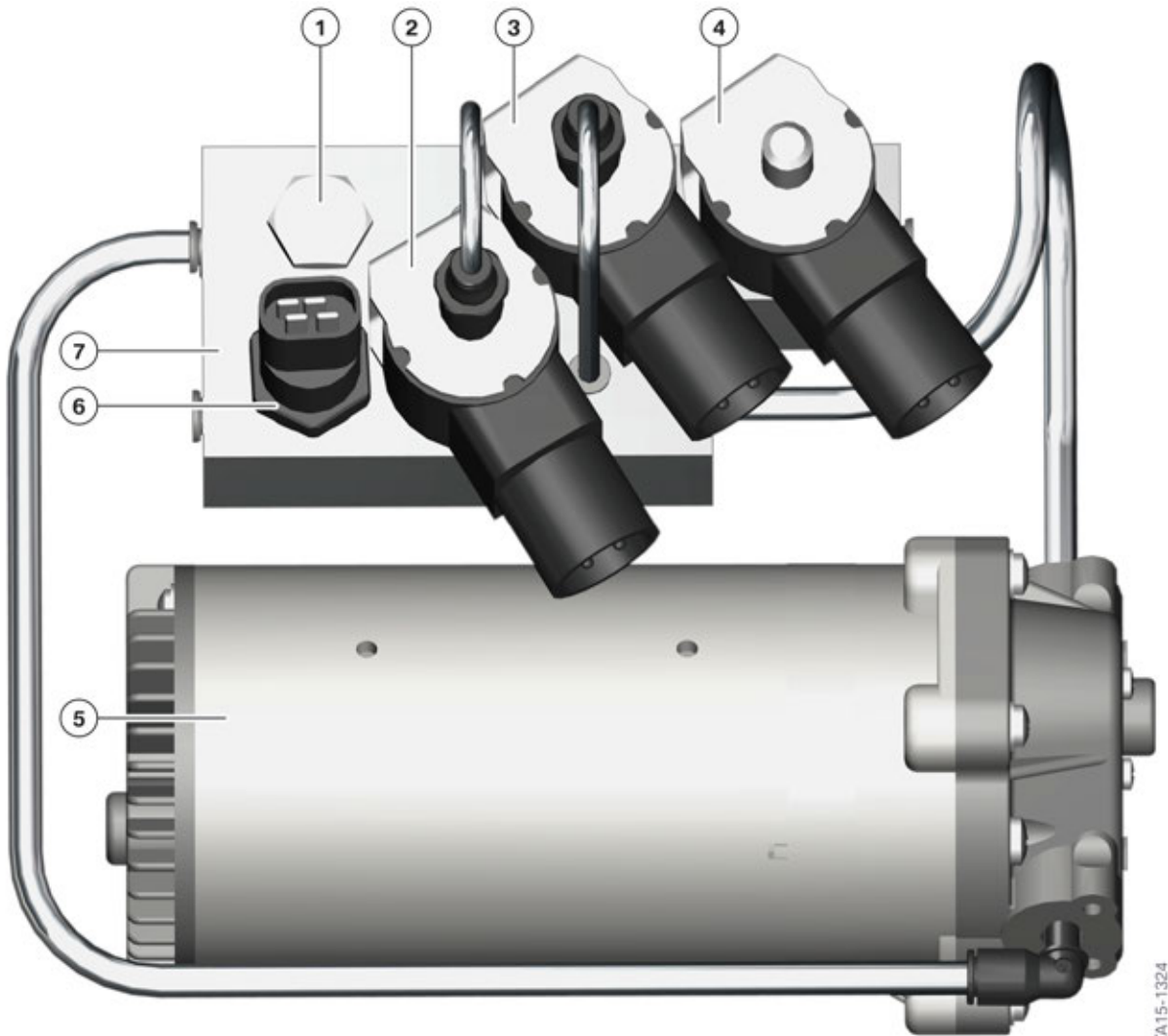

F82 GTS, valve block components

# F82 GTS Complete Vehicle

## 4. Drive

Index	Explanation
1	Screw for fine filter 10 µm
2	3/2-way valve 2
3	3/2-way valve 1
4	Shutoff valve
5	Water pump
6	Pressure sensor
7	Valve block

The water injection system can be diagnosed via the DME. The current information and specifications in the documents in the Integrated Service Technical Application (ISTA) must be observed in each case.

Further information on use and maintenance of the water injection system is provided in the Supplementary Owner's Handbook.

### 4.2. Engine electrical system

#### 4.2.1. Engine control

All components of the water injection system are integrated in the engine control. Just as with the S55 engine of the production vehicle in the F82 BMW M4 Coupé, the MEVD17.2.G engine control is used for the S55 engine in the F82 M4 GTS. When developing the MEVD17.2.G, the hardware was already designed to meet the requirements for water injection in the F82 M4 GTS.

# F82 GTS Complete Vehicle

## 4. Drive

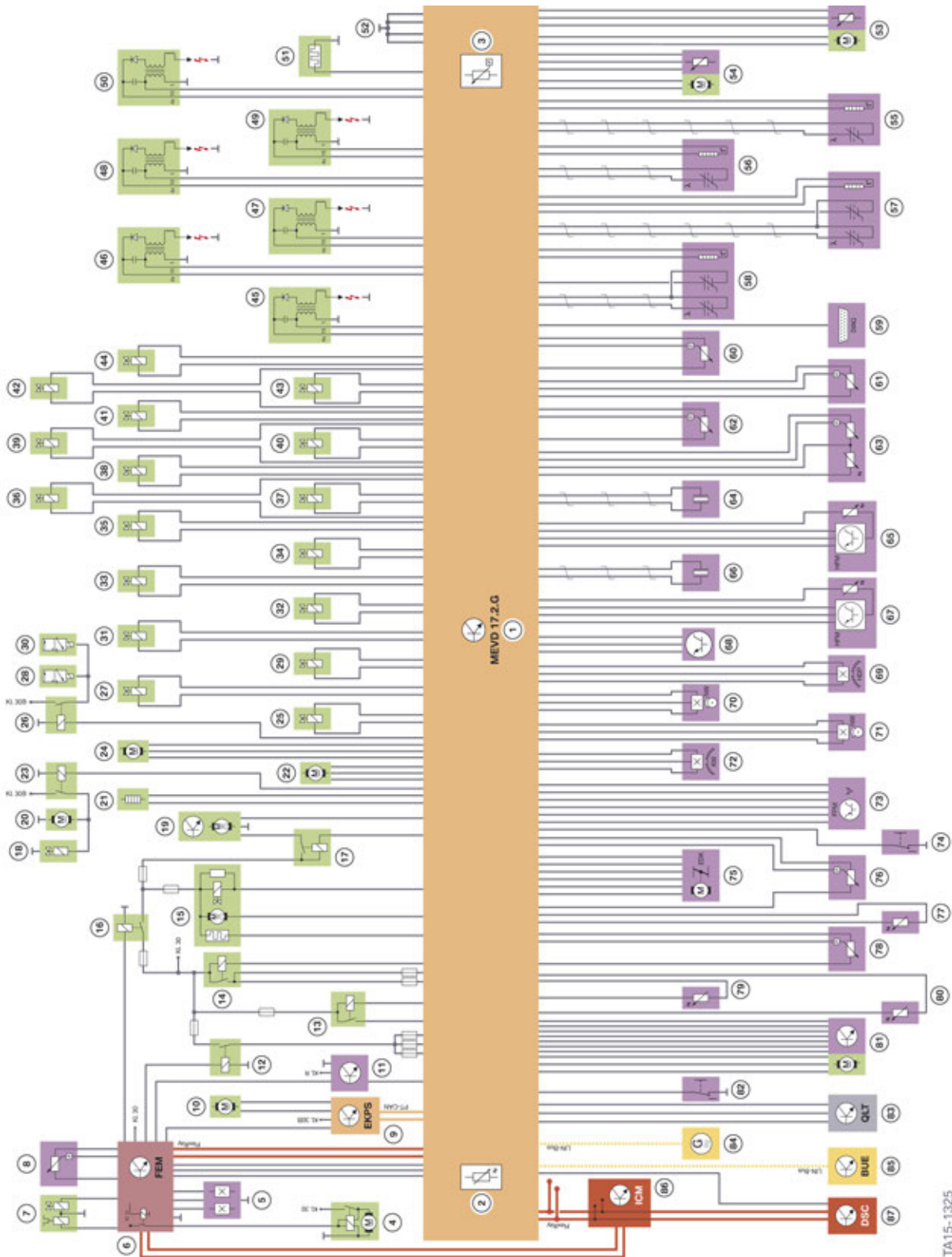

TA15-1325

F82 GTS, system wiring diagram MEVD17.2.G



# F82 GTS Complete Vehicle

## 4. Drive

Index	Explanation
1	DME, Valvetronic, direct fuel injection MEVD17.2.G
2	Temperature sensor
3	Ambient pressure sensor
4	Starter motor
5	Brake light switch
6	Front Electronic Module (FEM)
7	Air conditioning compressor
8	Refrigerant pressure sensor
9	Electronic fuel pump control
10	Electric fuel pump
11	Clutch module (not F82 M4 GTS)
12	Relay, terminal 15N
13	Relay, Valvetronic
14	Relay, ignition and fuel injection
15	Diagnostic module for tank leaks, (DMTL)
16	Relay, terminal 30B
17	Relay for electric fan
18	Shutoff valve for water injection
19	Electric fan
20	Water pump for water injection
21	Data-map thermostat
22	Electric coolant pump, exhaust turbocharger
23	Relay for water pump/shutoff valve in water injection system
24	Electric coolant pump, charge air cooling
25	Tank vent valve
26	Relay for 3/2-way valves in water injection system
27	VANOS solenoid valve, intake camshaft
28	3/2-way valve for water injection
29	VANOS solenoid valve, exhaust camshaft
30	3/2-way valve for water injection
31	Water injector 1
32	Water injector 2
33	Water injector 3
34	Oil pressure control valve
35	Quantity control valve, high pressure pump 1

# F82 GTS Complete Vehicle

## 4. Drive

<b>Index</b>	<b>Explanation</b>
36	Quantity control valve, high pressure pump 2
37	Electrical exhaust flap, cylinders 1 – 3
38	Electrical exhaust flap, cylinders 4 – 6
39 – 44	Injectors
45 – 50	Ignition coils
51	Engine ventilation heating
52	Ground connections
53	Electrical wastegate valve controller, cylinders 1 – 3
54	Electrical wastegate valve controller, cylinders 4 – 6
55	Oxygen sensor after catalytic converter, cylinders 1 – 3
56	Oxygen sensor after catalytic converter, cylinders 4 – 6
57	Oxygen sensor before catalytic converter, cylinders 1 – 3
58	Oxygen sensor before catalytic converter, cylinders 4 – 6
59	Diagnostic socket
60	Fuel low-pressure sensor
61	Intake-manifold pressure sensor after throttle valve
62	Rail pressure sensor
63	Charge air temperature and pressure sensor
64	Knock sensor, cylinders 1–3
65	Hot film air mass meter, cylinders 1 – 3
66	Knock sensor, cylinders 4-6
67	Hot film air mass meter, cylinders 4 – 6
68	Gear sensor (not F82 M4 GTS)
69	Position sensor, high pressure pump
70	Camshaft sensor, intake camshaft
71	Camshaft sensor, exhaust camshaft
72	Crankshaft sensor
73	Accelerator pedal module
74	Level sensor, water injection
75	Electromotive throttle controller
76	Pressure sensor, water injection
77	Coolant temperature sensor
78	Oil pressure sensor
79	Oil temperature sensor
80	Temperature sensor, water injection

# F82 GTS Complete Vehicle

## 4. Drive

Index	Explanation
81	Valvetronic servomotor
82	Engine dynamics button
83	Oil level sensor
84	Alternator
85	Battery supervision circuits (BUE)
86	Integrated Chassis Management (ICM)
87	Dynamic Stability Control (DSC)

### 4.3. Fuel supply

The suction strainer on the electric fuel pump was optimized for the F82 M4 GTS. This was necessary to guarantee reliable fuel supply even under conditions with high lateral and longitudinal acceleration forces. The other fuel supply components of the S55 engine in the F82 M4 GTS are common parts with the production vehicles.

### 4.4. Exhaust system

A separate exhaust system is used in the F82 M4 GTS after the catalytic converter near the S55 engine. The center silencer installed in the F82 BMW M4 Coupé is not installed on the F82 M4 GTS.

The exhaust system was designed for minimum exhaust gas pressure. Thanks to this dethrrotling of the exhaust system, it was possible to further optimize gas exchange efficiency. The exhaust system was also optimized in terms of lightweight construction. As a result, it was possible to reduce the weight of the system by 20% compared with the exhaust system in the F82 BMW M4 Coupé.

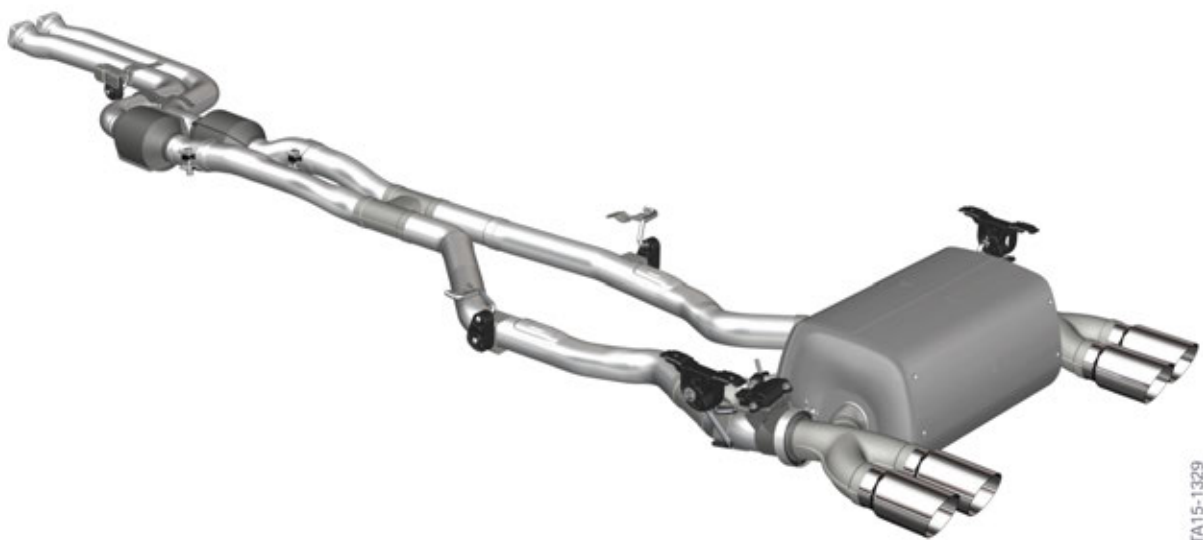

F82 GTS, exhaust system

TA15-1329

# F82 GTS Complete Vehicle

## 4. Drive

The rear silencer and the M-typical exhaust tailpipes are made of weight-optimized titanium (system supplier Eberspächer). In addition, the exhaust tailpipes have a purist titanium design and are embossed with the "M" designation.

The electrical exhaust flaps are activated directly by the DME by a pulse-width modulated signal.

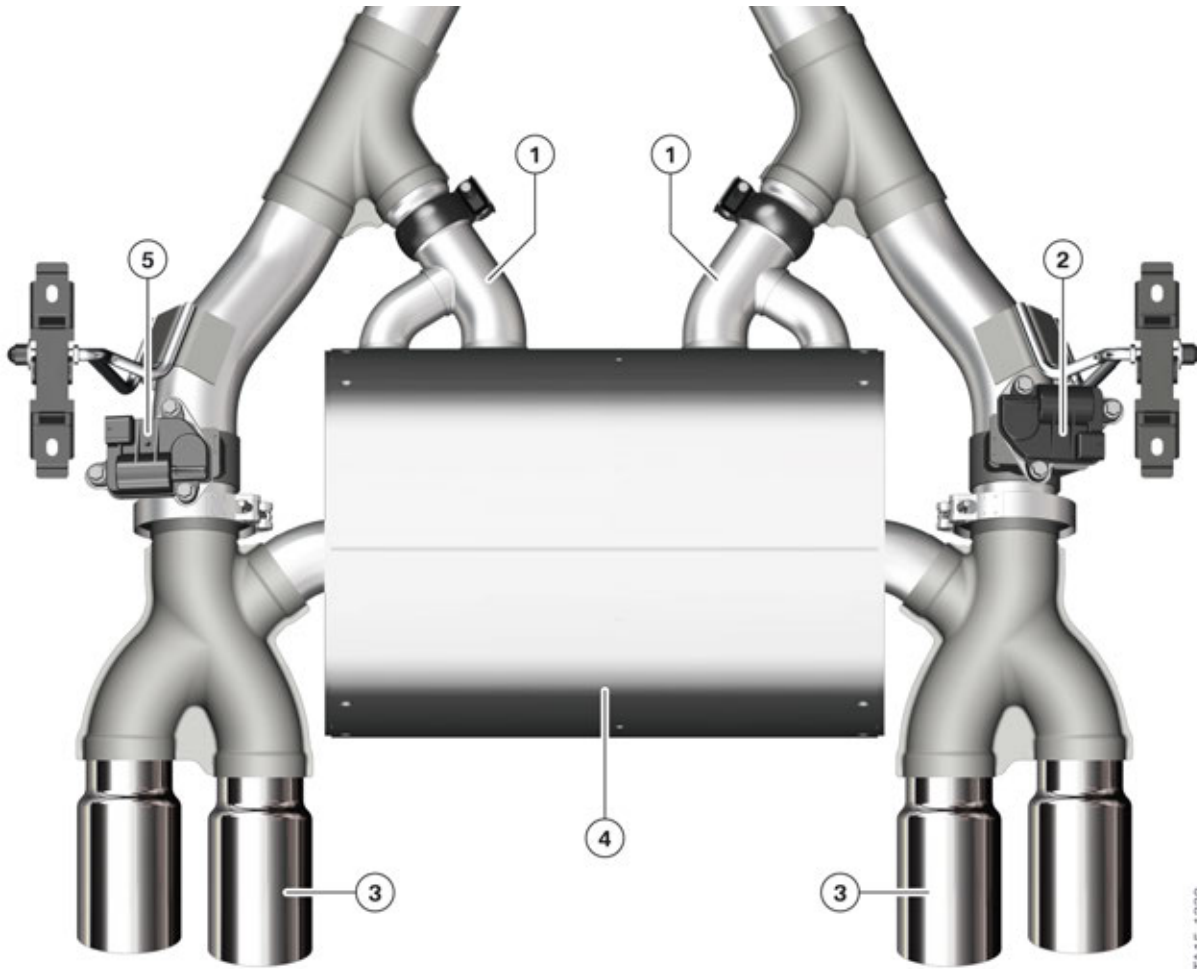

TA15-1330

F82 GTS, rear silencer

Index	Explanation
1	Bypass pipe
2	Electrical exhaust flap actuator (EAKS), right
3	Purist titanium twin tailpipes
4	Titanium rear silencer
5	Electrical exhaust flap actuator (EAKS), left

# F82 GTS Complete Vehicle

## 4. Drive

The exhaust flap can be opened by a pulse-width modulated signal of 10 % and closed with 90 % pulse width modulation. The end positions are the mechanical limit positions of the exhaust flap. Intermediate settings are not intended. The exhaust flap can be moved to the factory position for the installation by a pulse-width modulated signal (PWM) of 50 %. In order to ensure that the desired position is held even if the electric exhaust flap controller is not actuated for a long period, current is supplied again every 320 s +/- 10%. This acts in the direction of the limit position (duration of current supply: 50 ms +/- 5 ms).

Functional input variables for the calculation of the exhaust flap setting are:

- Vehicle speed
- Accelerator pedal angle
- Position of driving experience switch
- Engine temperature
- Gear mode

There is always a flow through the two tailpipe pairs by the bypass pipe (1) regardless of the flap position. Therefore, no varying blackening of the two tailpipe pairs occurs, which is typical of vehicles with exhaust flaps. In addition, the exhaust flaps in the tailpipe pairs are not visible through the exhaust tailpipes.

### 4.5. M DCT Drivelogic

For power transmission, the F82 M4 GTS uses the M double-clutch transmission M DCT Drivelogic also optionally available for the F82 BMW M4 Coupé without any design modifications. The shift characteristic of the 7-speed M DCT Drivelogic was made even more suitable for motor sports driving and matched specifically to the F82 M4 GTS.

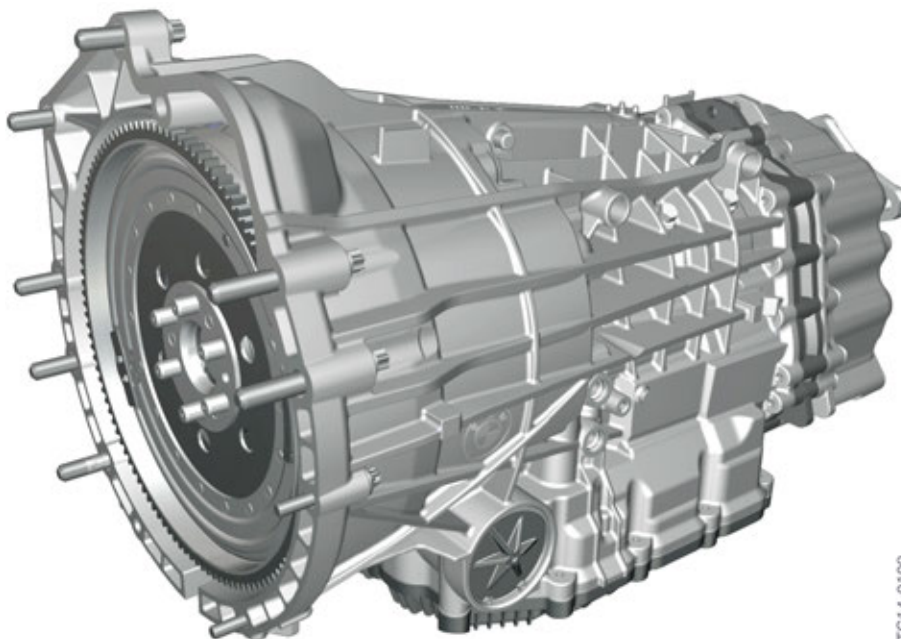

F82 GTS, M double-clutch transmission with M DCT Drivelogic

TC14-0109



# F82 GTS Complete Vehicle

## 4. Drive

### 4.5.1. M DCT Drivelogic and MDrive

The functional design and operation of the M gear selector switch are the same as in the F82 BMW M4 Coupé with M DCT Drivelogic.



F82 GTS, M DCT Drivelogic gear selector switch and driving dynamics button (example BMW M4 Coupé)

Index	Explanation
1	DSC button (including M dynamic mode)
2	Engine dynamics button
3	M gear selector lever
4	M DCT Drivelogic button
5	Servotronic button
6	Omitted on the F82 M4 GTS (adjustable threaded suspension)

### Drivelogic

The number of driving programs is the same as for the F82 BMW M4 Coupé.

After each change between Sequential mode and Drive mode the last selected driving program is active.

After each engine start driving program 1 is active in Drive mode.

### Drive mode

Three driving programs are available for selection:

- 1: Efficient drive
- 2: Dynamic drive
- 3: Sport drive

# F82 GTS Complete Vehicle

## 4. Drive

### Sequential mode

Three driving programs are also available here for selection:

1: Comfortable gear shifts

2: Sporty, fast gear shifts

3: Maximum shift speed and the requirement for the activation of the launch control

### 4.5.2. Launch Control

Launch Control enables optimal acceleration when driving off on a smooth roadway.



Launch Control should generally not be used during the first 5,000 km / 3100 miles when running in the vehicle (also see section Driving tips in the Owner's Handbook).

The 2,000 km / 1200 miles running-in check must have been completed and reset/confirmed with the Integrated Service Technical Application (ISTA) (do not reset via the instrument cluster service function, as otherwise the launch control is not enabled).

Premature wear occurs as a result of the high load on the vehicle components when using Launch Control.

### Pre-configuring

Sequence	Precondition/Action
1.	The vehicle must be stationary with the engine running at idle speed and at operating temperature (approx. 10 km / 6 mile warm-up drive).
2.	Deactivate Dynamic Stability Control (DSC).
3.	The Sequential mode and the third Drivelogic driving program are selected.
4.	Slightly press and hold the brake pedal with your left foot.
5.	Fully depress the accelerator pedal and hold in position.
6.	A flag symbol appears in the M instrument cluster (if not, check instructions and steps 1 - 5).
7.	An engine speed for pulling away of approx. 3,000 rpm is set. This can be modified up or down by a maximum 500 rpm in 100 rpm increments using the operating elements of the cruise control.
8.	Rapidly release the brake pedal within 3 s.

# F82 GTS Complete Vehicle

## 4. Drive

### Effect

- The Launch Control shifts independently up to the maximum speed with the shortest possible shifting times and shift points optimized for driving performance as long as the driver keeps the accelerator pedal fully depressed and a time limit of 22 seconds is not exceeded for acceleration.
- The start flag in the instrument cluster remains active.

### Automatic deactivation

- The driver releases (even if only temporary) the accelerator pedal from the fully depressed position during acceleration or the acceleration phase reaches a duration of 22 seconds.

Activation of Launch Control is not possible if one of these pre-configuration conditions is not met.

The start flag goes out with every deactivation and the automatic forced upshift is cancelled.

A defined distance must be travelled before each new activation of Launch Control.

Also at excessive transmission oil temperature (e.g. repeat Launch Control or race-like start), activation is blocked up until an acceptable temperature threshold is reached.

### 4.5.3. Wheelspin start



A wheelspin start should generally not be used during the first 5,000 km / 3100 miles when running in the vehicle (see also the chapter Driving tips in the Owner's Handbook).

The 2,000 km / 1200 miles running-in check must have been completed and reset/confirmed with the Integrated Service Technical Application (ISTA) (do not reset via the instrument cluster service function, as otherwise the wheelspin start function is not enabled).

Premature wear occurs as a result of the high load on the vehicle components when using the wheelspin start function.

### Preheating/Precooling

Sequence	Precondition/Action
1.	The vehicle must be stationary with the engine running at idle speed and at operating temperature (approx. 10 km / 6 mile warm-up drive).
2.	Deactivate Dynamic Stability Control (DSC).
3.	Select sequential or automated mode.
4.	Fully depress the accelerator pedal and hold in position.

# F82 GTS Complete Vehicle

## 4. Drive

### Effect

- The vehicle accelerates with maximum power and with corresponding wheel slip, depending on the surface.
- In sequential mode, the driver must shift up manually so that he does not drive against the speed limiter.
- In the case of automated upshifts, the M DCT carries out the upshifts independently.

In addition to the Launch Control and wheelspin start functions, the M DCT also offers additional M functions such as Stability Clutch Control (opening the clutch to stabilize the vehicle in the event of oversteer) or "Creep on Demand" (from vehicle standstill, the driver activates the "creep mode" familiar from automatic transmissions by touching the accelerator pedal).

### 4.5.4. Emergency gearbox release



---

The emergency gearbox release is not available like on the F80/F82 and F83. For towing of the vehicle, please observe the information in the Owner's Handbook for the vehicle.

---

### 4.5.5. Service information

#### Transmission oil circuit

Maximum cleanliness must be ensured if work has to be performed on the oil circuit of the twin-clutch gearbox, e.g. after an accident, or if the oil circuit has to be opened due to a repair. This includes:

- Carefully clean the external oil circuit areas before disassembling the components or opening the oil circuit.
- Immediately close off openings and lines after disassembly without delay using clean, original seal plugs. Do not use unsealed components or replacement parts of the oil circuit without checking for cleanliness and where possible competent repair.
- The workbay at which a M DCT is opened must be absolutely clean and protected against dirt contamination, also during work interruptions. For example by using appropriate, clean and lint-free cloths. **Refer to page 81**

#### Lifetime oil filling

As for the F80/F82 and the F83 with M DCT Drivelogic, **no** transmission oil change is currently planned at 2,000 km / 1,200 mile (running-in check) or at every third engine oil change.

#### Repair/Part exchange

Depending on the type of repair, the data status of the M DCT must be read out beforehand and read in again after the component has been replaced (e.g. replacement of mechatronics module).

Depending on the type of repair (e.g. dual clutch change), the "Neutral" gear selection position must be selected before the engine is stopped.

# F82 GTS Complete Vehicle

## 4. Drive



---

The current information and specifications in the documents in the Integrated Service Technical Application (ISTA) must be observed in each case.

---

### 4.6. Rear axle final drive

#### 4.6.1. Active M differential

This electronically/electromechanically controlled rear axle differential lock was developed especially for the F10 BMW M5 and is now also used in the F82 M4 GTS.

The M rear axle differential, size HAG 220 (crown wheel Ø 220 mm), is used with a M rear axle differential lock. The system designation is "regulated rear axle differential lock" and the control unit designation is GHAS (German acronym for **G**eregelte **H**inter **A**chsgetriebe **S**perre).

The gear ratio of the rear axle differential HAG 220 is 3.462:1.

This M rear axle differential II can be identified by an aluminium oil sump mounted from below and an electric motor which is visible from the outside.

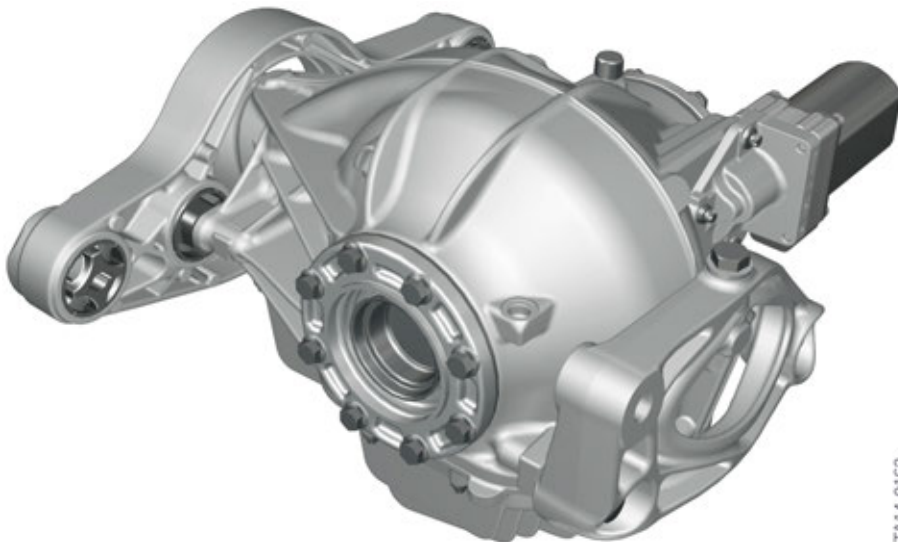

TA14-0162

F82 GTS, regulated rear axle differential lock, exterior view



# F82 GTS Complete Vehicle

## 4. Drive

### Demand-controlled lock

The lock is a demand-controlled rear-axle differential lock which is active in the following situations:

- Acceleration/pullaway.
- Differential speed at the rear axle for straight-ahead driving under load due to various coefficients of friction, left/right.
- Dynamic cornering.
- Power oversteer (drifting).
- Stabilization in coasting/overrun mode.

Further information on the active M differential is provided in the Technical Training Manual ST1402 F80/F82 Complete Vehicle.

### 4.6.2. Service information

- After replacement of the GHAS control unit, it is necessary to perform encoding (activation of vehicle-related characteristic curve) and then initial calibration. The fault memory must then be deleted.
- After the replacement of the entire M rear axle differential a calibration must be performed and then the fault memory must be deleted.
- For a replacement of the electric motor, electric motor plus intermediate gear or oil temperature sensor, only the fault memory must be deleted.

The final drive transmission oil is currently replaced at 2,000 km / 1,200 mile (running-in check) and at every 5th engine oil change. After this, the running-in check must be reset with the BMW workshop system Integrated Service Technical Application, ISTA.



---

The current information and specifications in the Integrated Service Technical Application (ISTA) must be observed.

---

# F82 GTS Complete Vehicle

## 5. Chassis and Suspension

### 5.1. Front axle and rear axle

In order to optimally transfer the outstanding engine performance to the road in every driving situation and also under extreme conditions, the F82 M4 GTS also features chassis and suspension technology that has been developed on the basis of extensive motor sports competence and experience. In terms of components and mounting, its chassis and suspension is based on the front and rear axle design of the F82 BMW M4 Coupé.

In deviation from this, an adjustable chassis developed especially for the F82 M4 GTS is installed. The adjustable chassis is built by KW Automotive GmbH according to the specifications of M GmbH and features dampers where the rebound and compression stages can be adjusted separately from each other. The adjustable chassis is bolted together with the body at the front using support rings.

The damper geometry and damper components on the front and rear axle with springs were adapted for use in the F82 M4 GTS and are provided with M-specific tuning.

The following components were adapted for the F82 M4 GTS:

- Twin-tube gas-oil pressure shock absorbers at the front and rear with adapted tube geometry.
- Valve block geometry for adjusting compression and rebound.
- Specific support bearings at the front in sealed uniball design with fixed camber and castor angles.
- Specific support bearings at rear.
- Rear bottom shock absorber eye screwed via a sealed uniball bearing.
- Separate swivel bearing at front to accommodate the shock absorber tube.
- Specific front anti-roll bar links adapted to shock absorbers.
- Specific spring geometry of the coil springs at front and rear.
- Stiffening plate cover made of CFRP.

# F82 GTS Complete Vehicle

## 5. Chassis and Suspension

### 5.1.1. Front axle

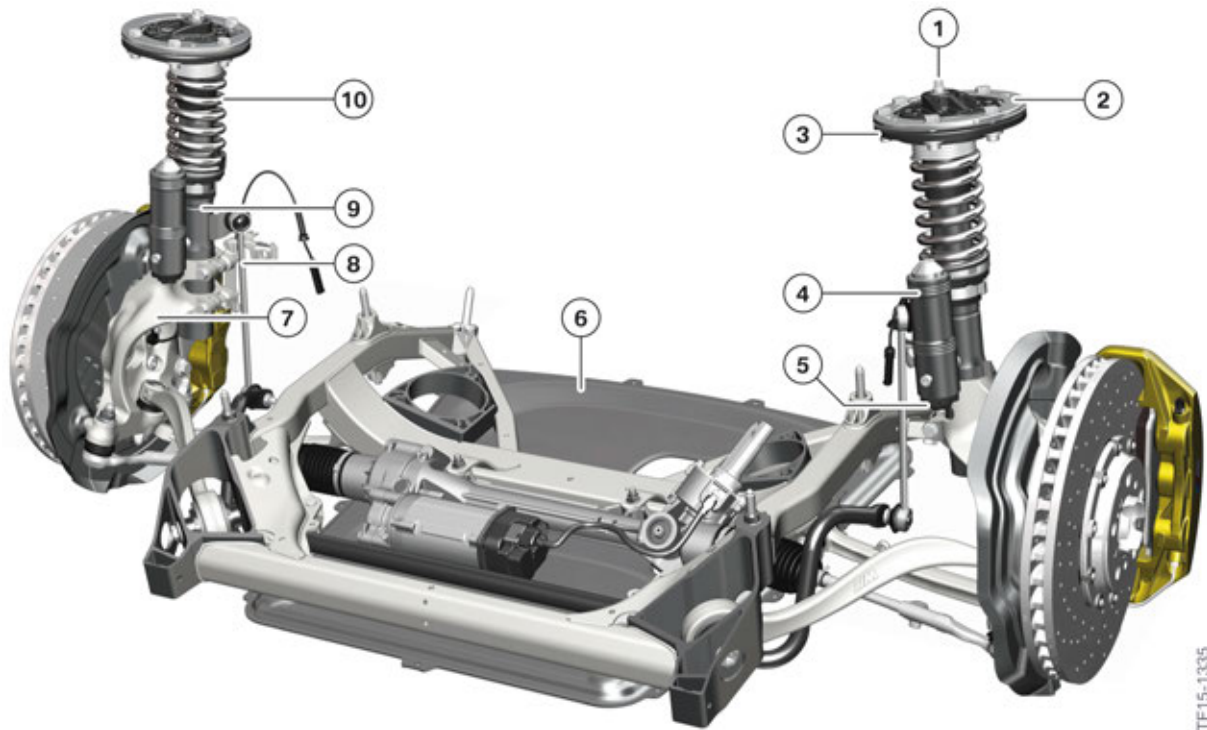

F82, BMW M4 GTS front axle

Index	Explanation
1	Hexagon for rebound adjustment
2	Support ring
3	Support bearing
4	Separate compression valve
5	Knurled wheels for compression stage (Larger wheel for high speed and the smaller wheel for low speed)
6	Stiffening plate
7	Swivel bearing
8	Anti-roll bar link
9	Twin-tube gas-oil pressure shock absorber
10	Coil spring

# F82 GTS Complete Vehicle

## 5. Chassis and Suspension

### Stiffening plate cover

A stiffening plate cover in CFRP is used on the F82 M4 GTS. (**C**arbon **F**iber **R**einforced **P**lastic)

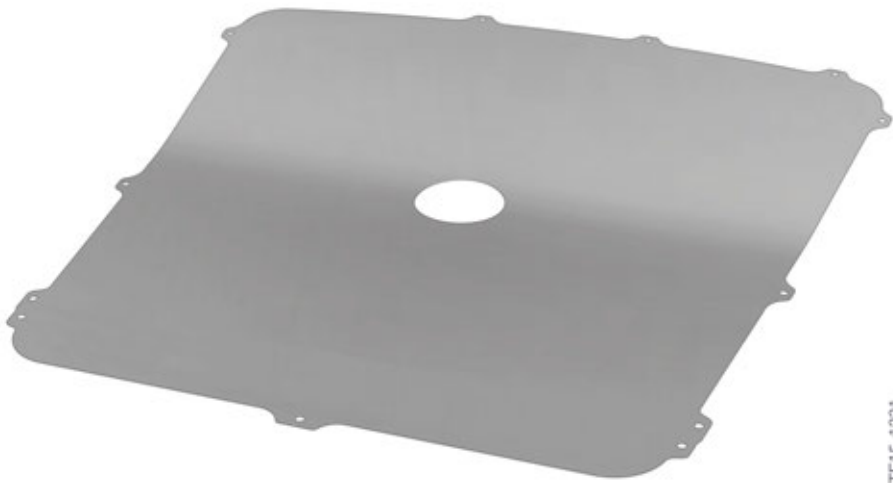

TF15-1331

F82, BMW M4 GTS stiffening plate cover

The stiffening plate cover optimizes the underbody air flow and improves the aerodynamics of the F82 M4 GTS.

# F82 GTS Complete Vehicle

## 5. Chassis and Suspension

### 5.1.2. Rear axle

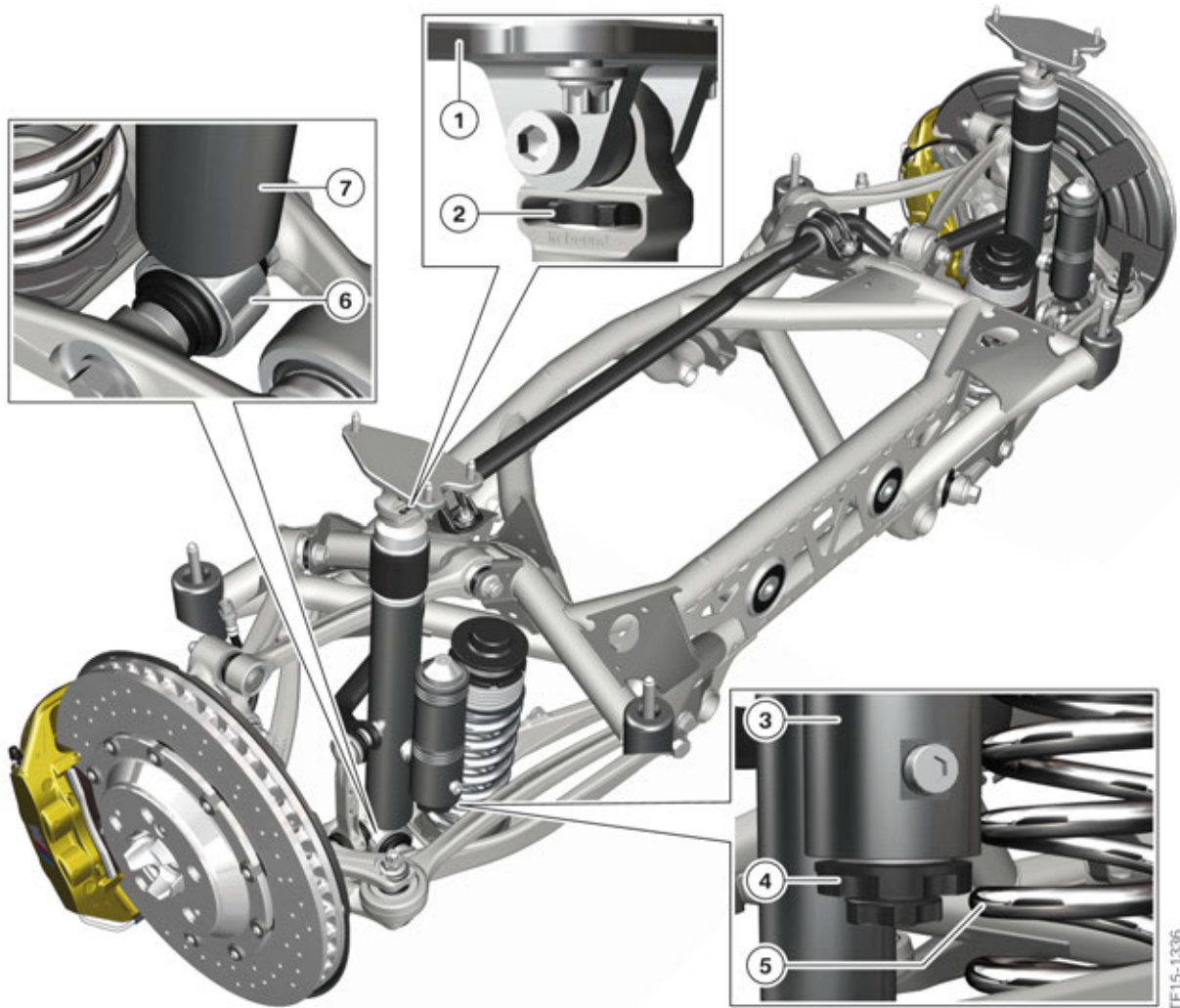

F82 GTS, rear axle

Index	Explanation
1	Support bearing
2	Knurled wheel for rebound
3	Separate compression valve
4	Knurled wheel for compression stage (Larger wheel for high speed and the smaller wheel for low speed)
5	Coil spring
6	Shock absorber mount, bottom
7	Twin-tube gas-oil pressure shock absorber

TF15-1336



# F82 GTS Complete Vehicle

## 5. Chassis and Suspension

### 5.2. Adjustable high-performance chassis and suspension

The chassis and suspension features the following additional adjustment options for an individual motor racing setup:

- Freely adjustable damping technology with 16 exact clicks for rebound adjustment.
- Freely adjustable damping technology with 6 clicks in the low-speed range for compression adjustment.
- 14 clicks in the high-speed range for compression adjustment.
- Continuously adjustable lowering of the front and rear axles (threaded spring struts on front axle/springs with height adjustment facility and damper on rear axle).

#### 5.2.1. Stepless lowering

The factory setting is optimal for both street operation and driving on race tracks (Nordschleife-Nürburgring). The factory settings must always be adjusted for operation on public roads. The factory setting is marked by so-called C clips. The C clips are installed between the lower edge of the spring cup and "race track setup" blocking ring. These clips can be removed in order to lower the chassis. If the C clips have been removed and the chassis adjusted away from the factory setting, this no longer corresponds to the approval for operation on public roads. A height adjustment automatically results in a change in camber and toe.

The vehicle height can be lowered by 15 mm at the front and 12 mm at the rear. It is necessary to undo the spring cup of the dampers to perform adjustment on the rear axle. This is due to the self-locking thread and a residual spring stress with the installed damper. If the "race track setup" blocking ring is removed, this may result in the vehicle being lowered by an inadmissible amount. The blocking ring is secured by means of a break away screw. The "race track setup" blocking ring is adjusted by BMW M GmbH and is provided with a break away screw. As a result, the ring can be removed only with difficulty or with force. In order to perform correct adjustment if the blocking ring has been removed, a new "race track setup" blocking ring is required. Adjustment must then be performed on a chassis and suspension measuring stand (alignment rack) in accordance with the procedure for spring - spring strut replacement.

# F82 GTS Complete Vehicle

## 5. Chassis and Suspension

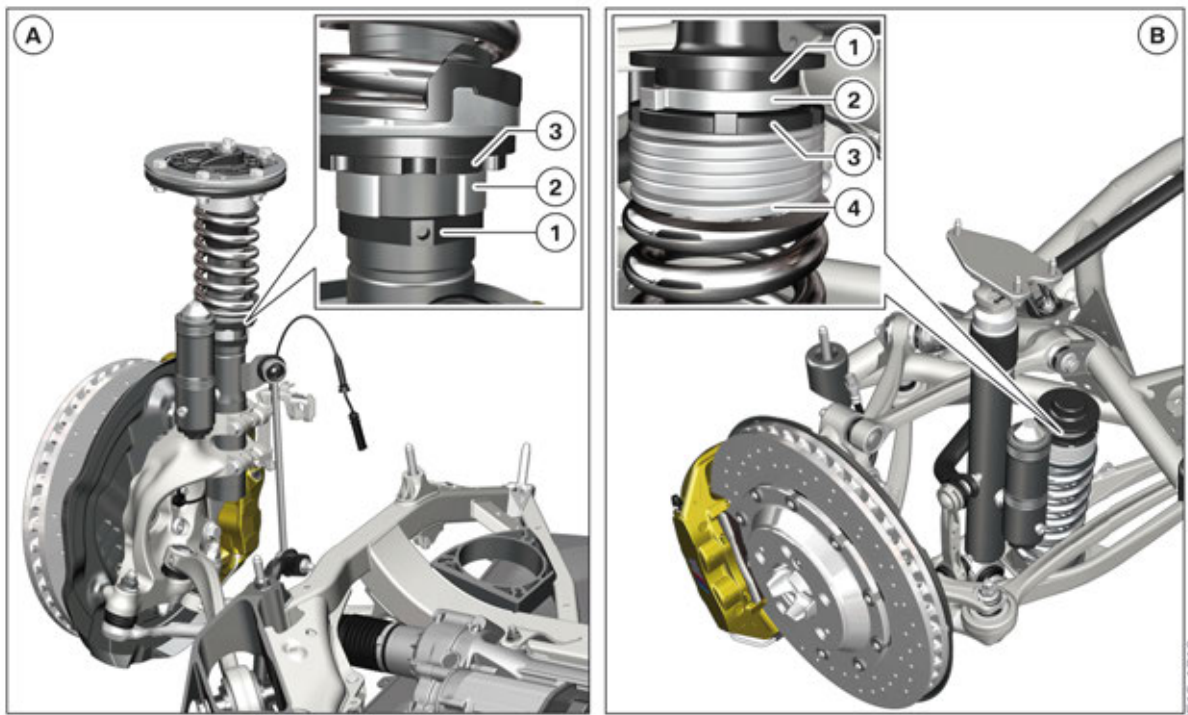

F82 GTS, stepless lowering

Index	Explanation
A	Components for stepless lowering at front
B	Components for stepless lowering at rear
1	Blocking ring
2	C clip ( Graphic A Front 15 mm, Graphic B Rear 7 mm)
3	Spring cup
4	Auxiliary spring

These basic factory settings along with the recommended race track settings, are also described in the Supplementary Owner's Handbook.

# F82 GTS Complete Vehicle

## 5. Chassis and Suspension

### Suspension Tool Kit

A hook/spanner wrench, knurled adjustment wheel and a 22 mm socket is included in the toolkit in the trunk.



Tool kit location, right side trunk



Tool kit for suspension height adjustment

### 5.2.2. Rebound

#### Effects of rebound on drivability

The rebound setting has a direct influence on the working speed of the piston rod when the suspension spring is recovering during the rebound process. In other words, it controls how quickly the suspension spring relaxes back to its initial position. The cross-sections of the rebound valves in the piston rod are opened further for softer handling and closed for a firmer setup.

# F82 GTS Complete Vehicle

## 5. Chassis and Suspension

- Low rebound forces improve ride comfort at slow driving speeds, but reduce stability and steering precision when driving fast, particularly with a corresponding setting.
- High rebound forces further improve handling at the front axle. This makes handling generally safer. However, high rebound forces may also reduce tire grip. Ride comfort is greatly restricted with high rebound forces.



Under no circumstances must the vehicle be driven with one axle at the maximum hard setting and the other axle at the maximum soft setting.

### Rebound adjustment

The knurled wheel supplied with the F82 M4 GTS is fitted at the top of the front shock absorber to adjust the rebound. Rebound adjustment at the rear is performed at the upper end of the piston rod using the integrated knurled wheel. Adjustment is performed from closed position (max. hardness) towards the soft setting. Closed condition is reached when the knurled wheel is turned clockwise (+) in hard direction until it reaches the limit position (number "0" on the knurled wheel). The effective adjustment range is 0 - 16 clicks in soft direction. The rebound damping is made softer by turning the wheel counter-clockwise (- opening).

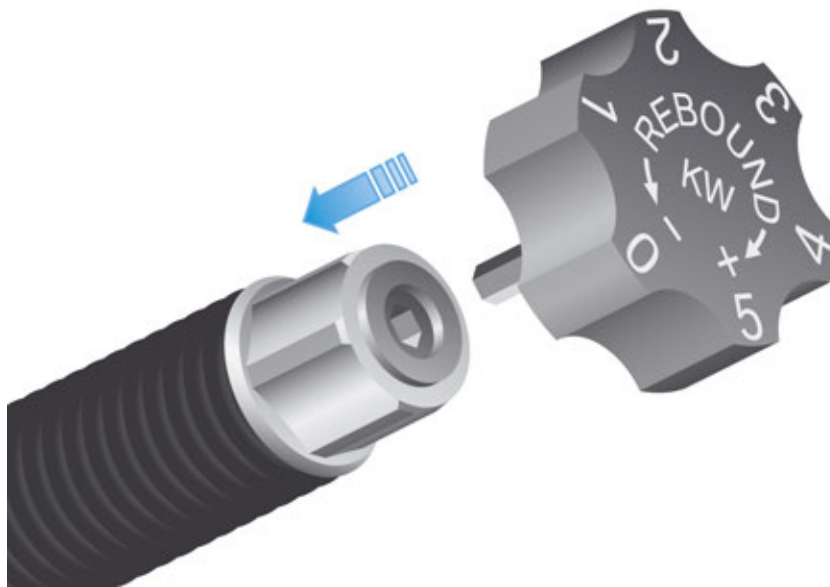

F82 GTS, supplied knurled wheel for front rebound adjustment



The knurled wheel operates a precision-engineered valve. Do not under any circumstances attempt to exceed the end of the adjustment range with force. This will damage the adjustment mechanism and necessitate exchange of the complete shock absorber.

The F82 M4 GTS is delivered with a basic rebound setting. If the shock absorbers are reset to the basic rebound setting, the values described in the Supplementary Owner's Handbook apply.

# F82 GTS Complete Vehicle

## 5. Chassis and Suspension

### 5.2.3. Compression stage

#### Effects of compression on drivability

The compression setting allows regulation of the immersion speed of the piston rod via the bottom valve (compression valve) of the shock absorber. If the compression valves are opened, the compression is reduced and the vehicle dives more quickly in response to steering wheel movements. The compression is increased if the compression valves are closed. The piston rods then dive more slowly and the vehicle becomes more stable. The compression setting thus affects the vertical force excitation of the vehicle.

The compression setting has a decisive influence on the handling and drivability of the vehicle.

The basic principle applies:

- A harder compression setting on the front axle makes the vehicle steering more precise and aggressive. A soft compression setting favours more good-natured drivability.
- A harder compression setting on the rear axle makes the vehicle more stable in the event of changes in direction and also counteracts an oversteering tendency. In contrast, a soft compression setting allows the rear end to self-steer more.
- Excessive compression results in uncomfortable rolling behavior and reduces grip.

However, due to the digressive properties of the pressure valve, a hard setting does not influence the compression behavior when driving quickly over shoulders or ground waves.



---

Under no circumstances must the vehicle be driven with one axle at the maximum hard setting in combination with the other axle at the maximum soft setting.

---

#### Low-speed/high-speed compression stage

The low-speed range of the compression stage influences the damping strength during compression at low piston rod speeds (max. 0.2 m/s). The high-speed compression range applies to all faster speeds of the damper piston rod.

#### Compression adjustment

The compression is adjusted at the lower end of the separate valve at the front and rear by means of two knurled wheels marked with “Lowspeed” and “Highspeed”. Both speed ranges can be adjusted separately from each other. Adjustment is performed from closed position (max. hardness) towards the soft setting. Closed condition is reached when the knurled wheel is turned clockwise (+) in hard direction until it reaches the limit position. The effective adjustment range is 0 - 6 clicks in the “Lowspeed” range towards soft and 0 - 14 clicks in the “Highspeed” range towards soft. The compression damping is made softer by turning the wheel counter-clockwise (-).



---

The knurled wheel operates a precision-engineered valve. Do not under any circumstances attempt to exceed the end of the adjustment range with force. This will damage the adjustment mechanism and necessitate exchange of the complete shock absorber.

---

# F82 GTS Complete Vehicle

## 5. Chassis and Suspension

The F82 M4 GTS is delivered with a basic compression setting. If the shock absorbers are reset to the basic compression setting, the values described in the Supplementary Owner's Handbook apply.

Further information on use and maintenance of the chassis and suspension is also provided in the Supplementary Owner's Handbook.

### 5.3. Wheel alignment

The following test conditions must be observed before wheel alignment:

- Only wheel and tire combinations approved by BMW fitted on the vehicle.
- Tread depth in accordance with specification. The tread depth may differ between left and right by a maximum of 1 mm to 2 mm on each axle.
- Tire pressure in accordance with specification (see label on vehicle).
- All chassis and suspension components must be technically fault-free.
- Condition of suspension and shock absorbers OK: visual inspection for breakage, etc.



A wheel alignment can be performed only taking into account the correct ride heights and wheel loads.

#### 5.3.1. Axle setting data

	Front axle	Rear axle
Ride height	624 mm ± 2 mm*	631 mm ± 2 mm*
Camber	-1° 45' ± 15'	-2° ± 10'
Total toe-in	10'	18'
Single wheel toe	5' ± 1'	9' ± 1'

\*Reset by adjusting the spring cups while taking into account the ride height tolerance and wheel loads.

#### 5.3.2. Procedure

##### 1. Adjust damping levels on front axle.

Rebound (support bearing): Turn knurled wheel to closed position, then open to basic setting as described in the Supplementary Owner's Handbook.

Compression (damper, bottom): Turn knurled wheel to closed position, then open to basic setting as described in the Supplementary Owner's Handbook.



# F82 GTS Complete Vehicle

## 5. Chassis and Suspension

### 2. Adjust damping levels on rear axle.

Rebound (support bearing): Turn knurled wheel to closed position, then open to basic setting as described in the Supplementary Owner's Handbook.

Compression (damper, bottom): Turn knurled wheel to closed position, then open to basic setting as described in the Supplementary Owner's Handbook.

### 3. Check ride heights

Drive vehicle from platform and carry out short test drive to relieve the axle mounting. After pre-adjustment as described above, the following ride height should be obtained on the vehicle:

- Front suspension: setpoint value 624 mm  $\pm$  2 mm tolerance adjustable via the spring cups (settling of vehicle taken into account).
- Rear suspension: setpoint value 631 mm  $\pm$  2 mm tolerance adjustable via the spring cups (settling of vehicle taken into account).

The vehicle can be measured according to the repair instructions only if the ride height is correct – otherwise operations must be repeated as describe above and the ride heights corrected by adjusting the spring cups.

#### Note:

- Front axle height adjustment - pitch 2 mm per thread turn. Adjustment of 1 mm at the spring strut results in a height change on the body of 1 mm.
- Rear axle height adjustment - pitch 2 mm per thread turn. Adjustment of 1 mm at the mounting plate results in a height change on the body of 1.6 mm.

### 4. Carry out wheel load optimization

- Place vehicle on wheel load weighing scales.
- Load driver's seat with 80 kg / 176 lbs.
- Vehicle with full fuel tank.

If the cross weight (front left-rear right/front right-rear left) is within  $\pm$  15 kg / 33 lbs, wheel alignment can be performed according to the repair instructions and the current nominal values.

If the cross weight is outside the tolerance, the wheel loads must be adjusted correctly by adjusting the spring cups, taking into account the ride height tolerances  $\pm$  2 mm. Correction should preferably be carried out on the rear axle.

### 5. Carry out wheel alignment on the front and rear axles.

- Front axle single wheel toe 5'  $\pm$  1'
- Rear axle single wheel toe 9'  $\pm$  1'
- Rear axle camber -2°  $\pm$  10'

# F82 GTS Complete Vehicle

## 5. Chassis and Suspension

### 6. Adjust wheel loads

- Place vehicle on wheel load weighing scales.
- Load driver's seat with 80 kg / 176 lbs.
- Vehicle with full fuel tank.

Adjustment of the cross weight (front left-rear right/front right-rear left) to  $\pm 15$  kg / 33 lbs and within  $\pm 2$  mm ride height tolerance.

If the cross weight is outside the tolerance, the wheel loads must be adjusted correctly by adjusting the spring cups, taking into account the ride height tolerances  $\pm 2$  mm. Correction should preferably be carried out on the rear axle.

### 7. Lock the blocking rings on the front axle

After correct wheel alignment, the blocking rings or ring on the front axle must be turned to the limit position at the bottom of the C clip. When the blocking ring is in the limit position, tighten the tear-off screw to finally secure the set screw until the tear-off screw tears off. This secures the blocking ring to prevent manipulation and prevents further lowering of the vehicle by the customer.

Undo spring cup by approx. a  $\frac{1}{4}$  turn so that it is easier to remove the spacer rings again later.

### 8. Lock the blocking rings on the rear axle

Lower corresponding rear axle side by removing the bottom fixing screw of the shock absorber eye. Take out the thread unit with the spring cup, blocking ring and vehicle mount. Fit C clip and turn the blocking ring to the limit position. When the blocking ring is in the limit position, tighten the tear-off screw to finally secure the set screw until the tear-off screw tears off. This secures the blocking ring to prevent manipulation and prevents further lowering of the vehicle by the customer.

Undo the spring cup by approx. a  $\frac{1}{4}$  turn so that it is easier to remove the spacer rings again later.

Fit the thread unit with spring cup, blocking ring, C clip and vehicle mount in the vehicle again. Screw together the rear axle side with the bottom shock absorber eye again.



---

If chassis and suspension components were replaced which make it necessary to replace or open the blocking ring, the new blocking ring must be secured again by a tear-off screw after correct wheel alignment.

---



---

For any service work required, the current information and specifications in the documents in the Integrated Service Technical Application (ISTA) must be observed in each case.

---

# F82 GTS Complete Vehicle

## 5. Chassis and Suspension

### 5.4. Brakes

The M carbon ceramic brake, familiar from the F82 BMW M4 Coupé as optional equipment, is fitted as the standard brake system on the F82 M4 GTS. Motor sports-oriented braided steel brake hoses are also used.

The M Carbon ceramic brake system is also called the C/SiC brake system.

Depending on the situation, this offers a further increase in active safety vis-a-vis the M Compound brake. In a direct comparison it also offers:

- Even more direct/spontaneous use of brake force.
- Maximum heat resistance even with continuous sporty operation.
- Higher fading stability.
- Greatly reduced wear on the brake discs.
- 7 kg / 15 lbs weight reduction of rotating wheel masses.
- Increased suitability for winter driving conditions thanks to corrosion resistance.

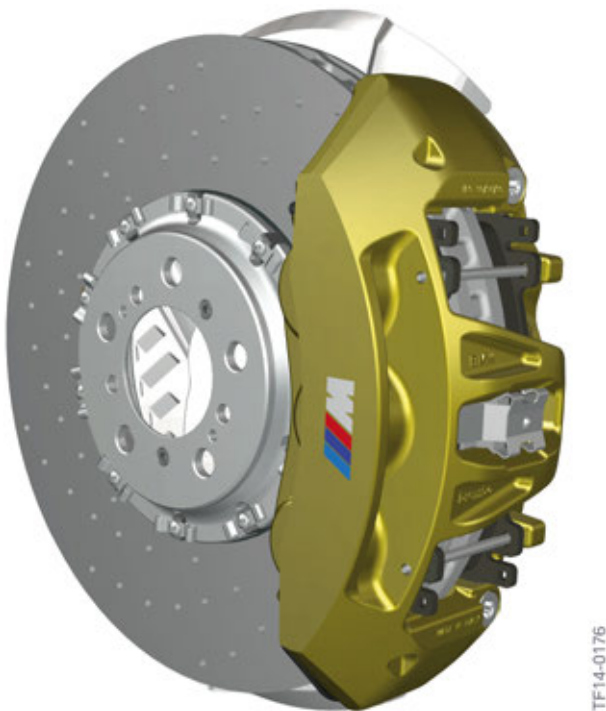

F82 GTS, M carbon ceramic brake on front axle

The brake discs are manufactured by Brembo SGL Carbon Ceramic Brakes GmbH.

# F82 GTS Complete Vehicle

## 5. Chassis and Suspension

Designation	Unit	F82 M4 GTS
Front brake		6 pistons, fixed caliper
Brake disc, front	[mm]	400 x 38
Rear brakes		4 pistons, fixed caliper
Brake disc, rear	[mm]	380 x 28
Parking brake		mechanical

Further information on the M carbon ceramic brake can be found in the Technical Training Manual ST1302 “M Carbon Ceramic Brake System” and in the Supplementary Owner's Handbook for the F82 M4 GTS.



For any service work required, the current information and specifications in the documents in the Integrated Service Technical Application (ISTA) must be observed in each case.

A specific setup of the driving dynamics system DSC (Dynamic Stability Control) takes into account the increased driving dynamics potential of the F82 M4 GTS.

### 5.5. Wheels and tires

Optimum transmission of both acceleration and braking torques is guaranteed by the 265/35 Cup tires on 19-inch M light-alloy rims at the front and 285/30 Cup tires on 20-inch M light-alloy rims at the rear in a new, unique design.

Designation	F82 M4 Coupé	F82 M4 GTS
Light alloy EH2+ wheel rims at front (forged)	9J x 18 IS 29 Styling 513M	9.5 x 19 IS 29 Styling 666M
Light alloy EH2+ wheel rims, at rear (forged)	10J x 18 IS 40 Styling 513M	10.5 x 20 IS 40 Styling 666M
Front tires (Michelin Pilot Sport Cup 2)	255/40 ZR 18	265/35 ZR 19
Rear tires (Michelin Pilot Sport Cup 2)	275/40 ZR 18	285/30 ZR 20

# F82 GTS Complete Vehicle

## 5. Chassis and Suspension

### 5.5.1. Wheels

As standard, forged 19" M light-alloy wheels are used at the front and 20" M light-alloy wheels at the rear in 666M styling.



F82 GTS, light-alloy wheels in styling 666M

### 5.5.2. Cup tires

Michelin Pilot Sport Cup 2 tires designed for the race track which also meet the legal regulations for use on public roads. These tires were optimized specifically for use on the race track in dry conditions. On wet roads or race tracks with a risk of hydroplaning, it is necessary to drive at an appropriate speed and with activated driving dynamics systems.

The Michelin Pilot Sport Cup 2 tires are similar to a pure sport tire in terms of design, structure and rubber compound, but have a dominant influence on the excellent drivability of the F82 M4 GTS thanks to their very heat-resistant rubber compound.

# F82 GTS Complete Vehicle

## 5. Chassis and Suspension



TF15-1033

F82 GTS, Cup tire tread

The Michelin Pilot Sport Cup 2 tires are designed for maximum dry performance and offer significantly more potential for longitudinal and lateral acceleration and for precision steering than comparable standard tires. They have an asymmetrical tread pattern with a high positive pattern share (large contact surface = few recesses). The tires wet performance is reduced. The customer must be informed about this by an additional sheet as an appendix to the purchase contract when purchasing the F82 M4 GTS. The Michelin Pilot Sport Cup 2 tires have the following properties and advantages:

- **High tread depth** Improved grip and later hydroplaning tendency while driving on normal roads.
- **Two-component technology** Two different rubber compounds on the outside and inside of the tire tread surface. The outer side tire compound consists of highly linked elastomers which offer optimum grip and abrasion protection in tight corners. The tire inner side comprises hard elastomers which improve steering precision and offer optimum grip on wet road surfaces.



# F82 GTS Complete Vehicle

## 5. Chassis and Suspension



---

The following must be observed before intensive race track use:

- Always check the condition of the tires for wear and possible damage.
- Warm up the tires by driving moderately for a few laps.
- The optimum tire pressure of the Michelin Pilot Sport Cup 2 is between 2.0 bar (29 psi) and 2.9 bar (42 psi) at the front and rear.
- Never drive with a tire pressure of less than 2.0 bar (29 psi).

Observe the following after race track use and before driving on public roads:

- Adjust the tire pressure recommended by the vehicle manufacture on the cold tire.
- Allow the tire to cool down before making corresponding tire pressure adjustments.
- Always check the condition of your tires to make sure that they comply with the legal regulations for use on public roads.
- If the driving dynamics systems were deactivated, activate these again.

### TIRE PRESSURE RECOMMENDATIONS

The correct tire pressures for approved tire sizes can be found on the door post of the driver's door. Further information on tire pressures is provided in the Supplementary Owner's Handbook. The pressure specifications apply for tires at ambient temperature.

---



### ATTENTION

- If the Michelin Pilot Sport Cup 2 tires are not used for an extended period, it is recommended to remove the wheels from the vehicle and to reduce the tire pressure to half the usual value.
- The tires should be stored in a clean, dry and dark location in accordance with the recommendations from Michelin and at temperatures above 0 °C / 32 °F.
- The use, storage or handling of Michelin Pilot Sport Cup 2 tires at ambient temperatures below minus -10 °C / 14 °F should be avoided. Elements of the rubber compound may be damaged under these conditions. This will impair the performance characteristics of the tire and may even cause cracks or breaks in the tire tread which make further use of the tire impossible.
- Never use a tire that has cracks, breaks or other damage on the tire tread or sidewalls. In case of doubt, the customer should consult BMW Service.

# F82 GTS Complete Vehicle

## 5. Chassis and Suspension

- In the case of intensive race track use, the tires or tire casing may become damaged after extended driving and frequent driving over the curb.
  - The tires must be checked carefully if they have been frequently driven over curb or the vehicle has left the track. In such a case, it is necessary to remove the tire from the wheel in order to inspect both the outer and inner sides of the tire.
  - A visual check of the tires must be performed after every “run” and before returning to the track.
-

# **F82 GTS Complete Vehicle**

## **6. Vehicle Electrical System**

### **6.1. Active Sound Design ASD**

The Active Sound Design ASD is not installed in the F82 M4 GTS.

### **6.2. Heating and air conditioning system**

The integrated 1/1 single zone heating/air conditioning system is used in the F82 M4 GTS. The integrated 2/1 zone automatic heating/air conditioning system is not available for the F82 M4 GTS for weight reasons.

In the zone specification the first number denotes the number of controllable temperature zones (temperature selector wheels) and the second number the number of controllable airflow volume and air distribution zones (separate fan settings).

### **6.3. Radio and speaker system**

The radio and speaker system was also reduced to a minimum for weight and concept reasons. As a result, 2 central bass speakers are used under the front seats. These are supplemented by 2 mid-range speakers on the left and right of the storage shelf supported by 2 tweeters which complete the audio system in the F82 M4 GTS.

# F82 GTS Complete Vehicle

## 6. Vehicle Electrical System

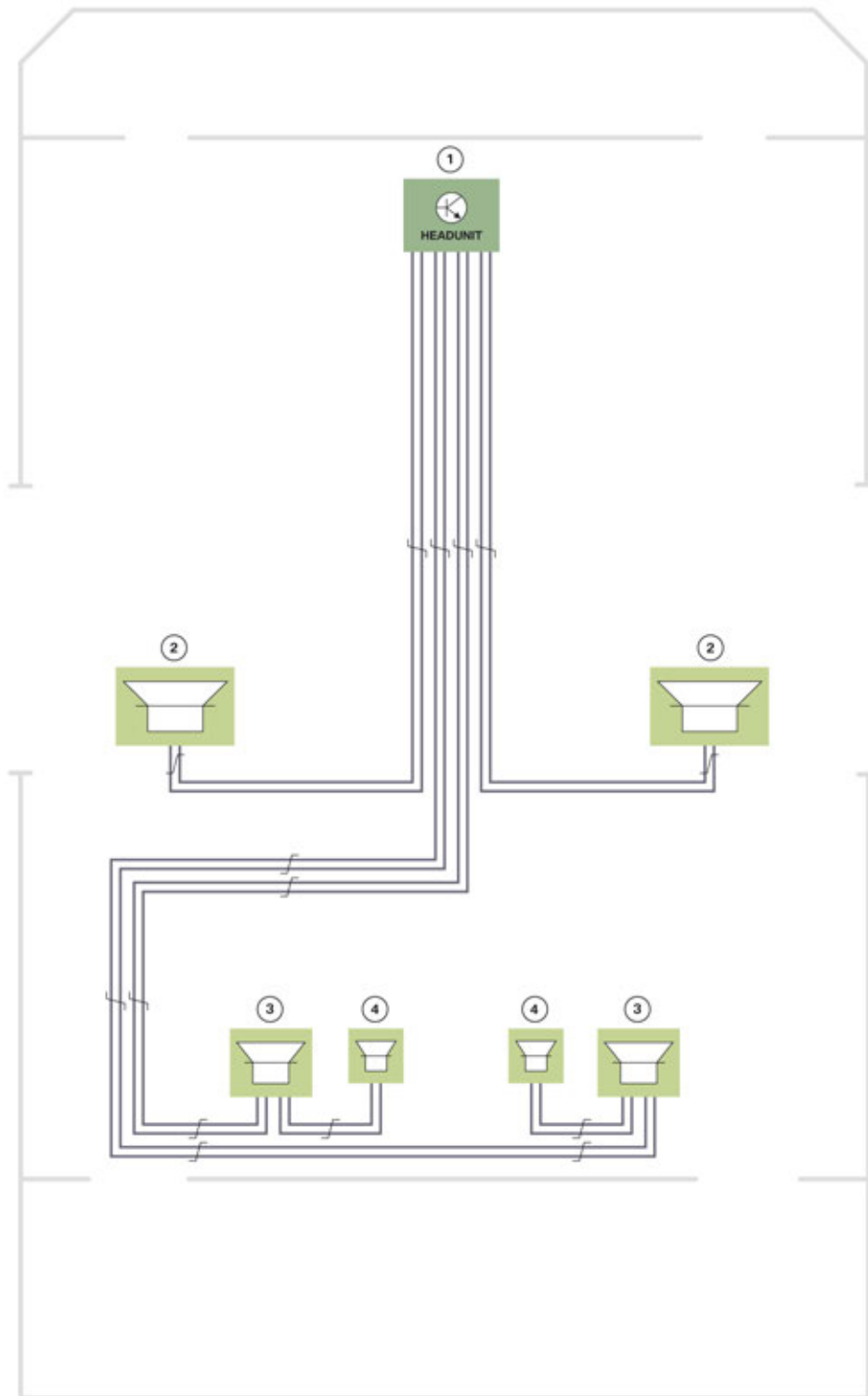

F82 GTS, audio system

TE15-1697

# F82 GTS Complete Vehicle

## 6. Vehicle Electrical System

---

<b>Index</b>	<b>Explanation</b>
1	Head unit
2	Central bass (under front seats)
3	Mid-range speakers (in parcel shelf)
4	Tweeters (in parcel shelf)

---

# F82 GTS Complete Vehicle

## 7. Information for Service

### 7.1. F82 M4 GTS

- At the vehicle handover, the customer must sign a handover record which informs him about the special features of the F82 BMW M 4 GTS. The customer must confirm the content of this handover record with his signature. In the handover record, the customer is informed, among other things, about reduced comfort in the areas of drive system and chassis and suspension as well as about the deviating conditions for use of the F82 M4 GTS.

### 7.2. Replacement part orders

- The complete replacement parts supply for the F82 M4 GTS is done through the central BMW Group Parts organization. As usual, the vehicle must be identified via the Electronic Parts Catalogue with the vehicle identification number. The GTS-specific parts are also output via the EPC with the part number for the F82 M4 GTS.
- Replacement part supply for specific parts of all predecessors of the F82 M4 GTS is handled through BMW M GmbH. Supplementary part numbers for the M3 GTS and CRT can be obtained from the ASAP "Aftersales Assistance Portal". All BMW M4 common parts can be identified directly in the Electronic Parts Catalogue and ordered from the central BMW Group Parts organization.

### 7.3. Body

- The prescribed settings of the front spoiler for street use as well as the recommendations for motor sports settings and tightening torques are described in the Supplementary Owner's Handbook.
- The prescribed settings of the rear spoiler for street use as well as the recommendations for motor sports settings and tightening torques are described in the Supplementary Owner's Handbook of the F82 M4 GTS.
- In general, the further the front spoiler is extended, the larger the inclination angle of the rear spoiler should be. Otherwise, a safe vehicle balance is not guaranteed at high speeds.
- Adjustments to the rear spoiler must be performed only when the trunk is closed. When undoing the screws, it must be ensured that the rear spoiler does not tip down.

### 7.4. Seat belts

- The six-point seat belts for driver and front passenger must be fitted only for race track operation. Separate instructions for use/installation instructions for the six-point seat belts are required.
- Three-point seat belts are installed from the factory and must be used for street operation.



# F82 GTS Complete Vehicle

## 7. Information for Service

### 7.5. S55B30T0 engine

- Like on the F80/F82 and F83, the engine oil is currently renewed at 2,000 km / 1200 mile (running-in check). After this, the running-in check must be reset with the BMW workshop system Integrated Service Technical Application ISTA.
- Changed engine oil fill quantity for the S55 engine in the F82 M4 GTS. The fill quantity for an engine oil change with filter is 7 liters. Engine oil fill quantity without filter exchange 6.5 liters.

### 7.6. Water injection

- When the engine is switched off and the water injection system is drained, operating noises occur which may be perceived by the customer. These operating noises cannot be avoided due to the operating principle of the system.
- When filling the water injection system, only commercially available distilled water (demineralized - decalcified) must be used for the F82 M4 GTS. Other fluid, mixtures or mixtures with alcohols are not approved by BMW.
- The 10 µm fine filter in the valve block can be removed and installed by means of the hexagon screw. The fine filter should be replaced at every 2nd oil service/20,000 miles.
- The water injection system can be diagnosed via the DME. The current information and specifications in the documents in the Integrated Service Technical Application (ISTA) must be observed in each case.
- The water consumption depends greatly on the vehicle operating conditions and varies correspondingly. As a rule of thumb, a consumption of 0.6 / – 1 liter per 100 km or 0.15 gallons – 0.26 gallons per 62 miles can be expected on the race track. In the case of dynamic motorway driving (engine speed > 5000 rpm and high load) in everyday use, it will probably be necessary to top up with water at only every 5th refuelling operation.
- If water injection is no longer available, the engine power will then correspond to the standard power of the S55 engine.  
Further information on use and maintenance of the water injection system is provided in the Supplementary Owner's Handbook.

### 7.7. M DCT

Maximum cleanliness must be ensured if work has to be performed on the oil circuit of the twin-clutch gearbox, e.g. after an accident, or if the oil circuit has to be opened due to a repair. This includes:

- Carefully clean the external oil circuit areas before disassembling the components or opening the oil circuit.
- Immediately close off openings and lines after disassembly without delay using clean, original seal plugs. Do not use unsealed components or replacement parts of the oil circuit without checking for cleanliness and where possible competent repair.
- The workbay at which an M DCT is opened must be absolutely clean and protected against dirt contamination. If interrupted during repairs, clean and lint free cloths must be used to protect exposed components.

# F82 GTS Complete Vehicle

## 7. Information for Service

As for the F80/F82 and the F83 with M DCT Drivelogic, **no** transmission oil change is currently planned.

Depending on the type of repair, the data status of the M DCT must be read out beforehand and read in again after the component has been replaced (e.g. replacement of mechatronics module).

Depending on the type of repair (e.g. dual clutch change), the "Neutral" gear selection position must be selected before the engine is stopped.

The emergency gearbox release is not installed like on the F80/F82 and F83. For towing away, please observe the information in the Owner's Handbook of the vehicle.

### 7.8. Launch Control and wheelspin start

- The Launch Control and wheelspin start functions should generally not be used during the first 5,000 km / 3,100 miles when running in the vehicle (see also the chapter Driving tips in the Owner's Handbook).
- The 2,000 km / 1,200 mile running-in check must have been completed and reset/confirmed with the Integrated Service Technical Application (ISTA) (do not reset via the instrument cluster service function, as otherwise the Launch Control and wheelspin start functions are not enabled).
- Premature wear occurs as a result of the high load on the vehicle components when using the Launch Control and wheelspin start functions.

### 7.9. Active M differential

- For a replacement of the GHAS control unit an encoding (activation of vehicle-related characteristic curve) and then an initial calibration are necessary and then the fault memory must be deleted.
- After the replacement of the entire M rear axle differential a calibration must be performed and then the fault memory must be deleted.
- For a replacement of the electric motor, electric motor plus intermediate gear or oil temperature sensor, only the fault memory must be deleted.
- The final drive differential oil is currently replaced at 2,000 km / 1,200 miles (running-in check) and at every fifth engine oil change. After this, the running-in check must be reset with the BMW workshop system Integrated Service Technical Application ISTA.

### 7.10. Adjustable high-performance chassis and suspension

- Under no circumstances must the vehicle be driven with one axle at the maximum hard damper setting in combination with the other axle at the maximum soft setting.
- The knurled wheel for damper adjustment operates a precision-engineered valve. Do not under any circumstances attempt to exceed the end of the adjustment range with force.

# F82 GTS Complete Vehicle

## 7. Information for Service

This will damage the adjustment mechanism and necessitate the exchange of the complete shock absorber.

- The F82 M4 GTS is delivered with a basic compression and rebound setting. If the shock absorbers are reset to the basic compression and rebound setting, the values described in the Supplementary Owner's Handbook apply.
- A hook wrench for lowering and a knurled wheel with hexagon for adjusting the damper are included in the toolkit for this purpose.
- Further information on use and maintenance of the adjustable high-performance chassis and suspension is provided in the Supplementary Owner's Handbook.

### 7.11. Wheel alignment

- A wheel alignment can be performed only by taking into account the correct ride heights and wheel loads.
- If chassis and suspension components were replaced which make it necessary to replace or open the blocking ring, the new blocking ring must be secured again by a break off screw after correct wheel alignment.

### 7.12. Tires

- If the Michelin Pilot Sport Cup 2 tires are not used for an extended period, it is recommended to remove the wheels from the vehicle and to reduce the tire pressure to half the usual value.
- The tires should be stored in a clean, dry and dark location in accordance with the recommendations from Michelin and at temperatures above 0 °C / 32 °F.
- Use, storage or handling of Michelin Pilot Sport Cup 2 tires at ambient temperatures below minus -10 °C / +14 °F should be avoided. Elements of the rubber compound may be damaged under these conditions. This will impair the performance characteristics of the tire and may even cause cracks or breaks in the tire tread which make further use of the tire impossible.
- Never use a tire that has cracks, breaks or other damage on the tire tread or sidewalls. In case of doubt, the customer should consult BMW Service.
- In the case of intensive race track use, the tires or tire casing may become damaged after extended driving and frequent driving over the curb.
- The tires must be checked carefully if they have been frequently driven over curb or the vehicle has left the track. In such a case, it is necessary to remove the tire from the wheel in order to inspect both the outer and inner sides of the tire.
- A visual check of the tires must be performed after every "run" and before returning to the track.
- The correct tire pressures for approved tire sizes can be found on the door post of the driver's door. Further information on tire pressures is provided in the Supplementary Owner's Handbook.
- Further information on use and maintenance of the tires is provided in the Supplementary Owner's Handbook.





Bayerische Motorenwerke Aktiengesellschaft  
Qualifizierung und Training  
Röntgenstraße 7  
85716 Unterschleißheim, Germany